



4 mavzu:

**IX-XIII asrlarda O'rta Osiyo
madaniyati va san'ati**

Reja:

- IX-X asrlarda madaniy taraqqiyot omillari
- Me'morchilik va amaliy san'at taraqqiyoti

Buxoro arki devorining saqlanib qolgan qismi



- Qirqqiz qal'asi.
Surxondaryo.



Samoniylar
maqbarasi

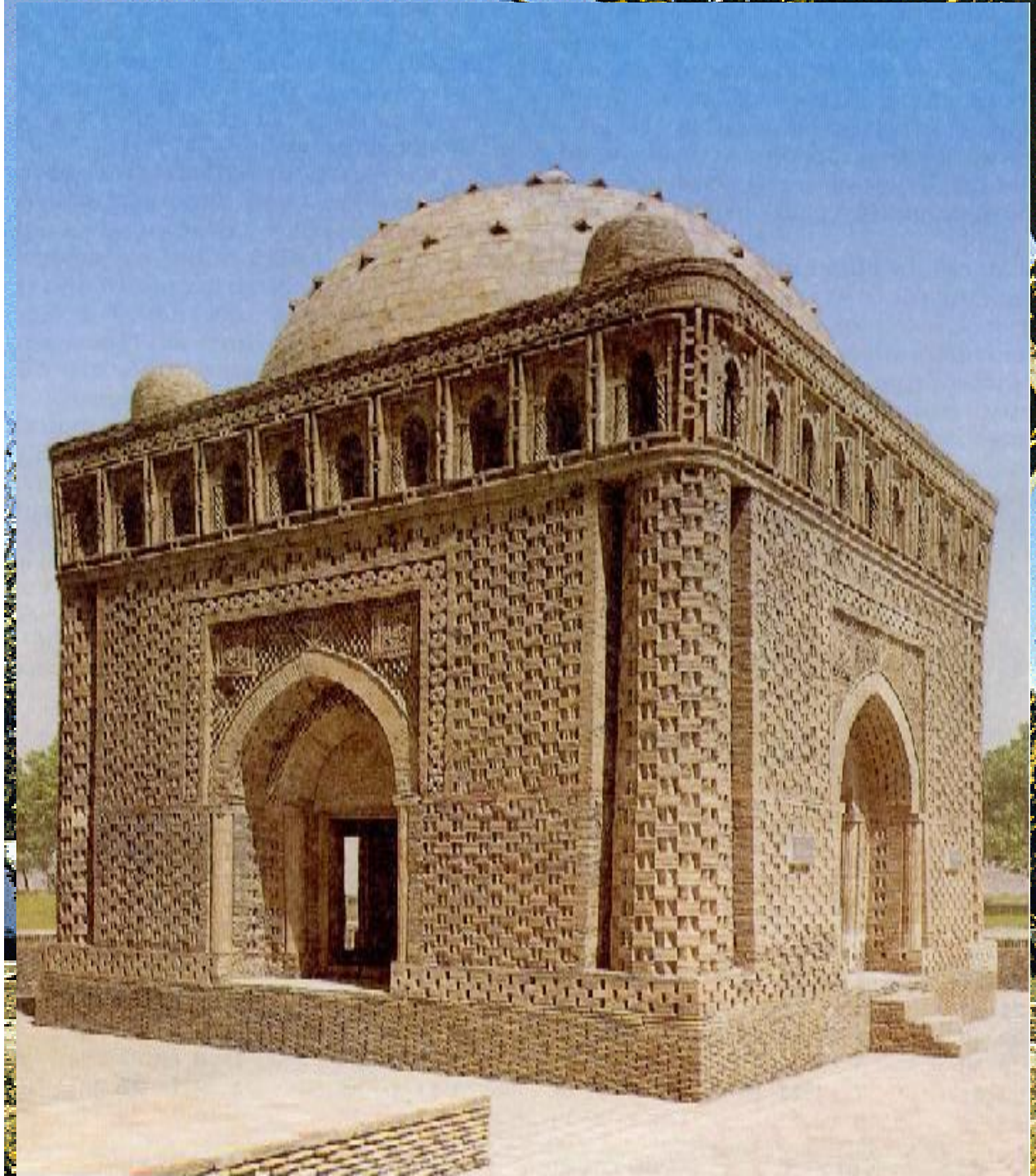



Oq ostona bobo maqbarasi

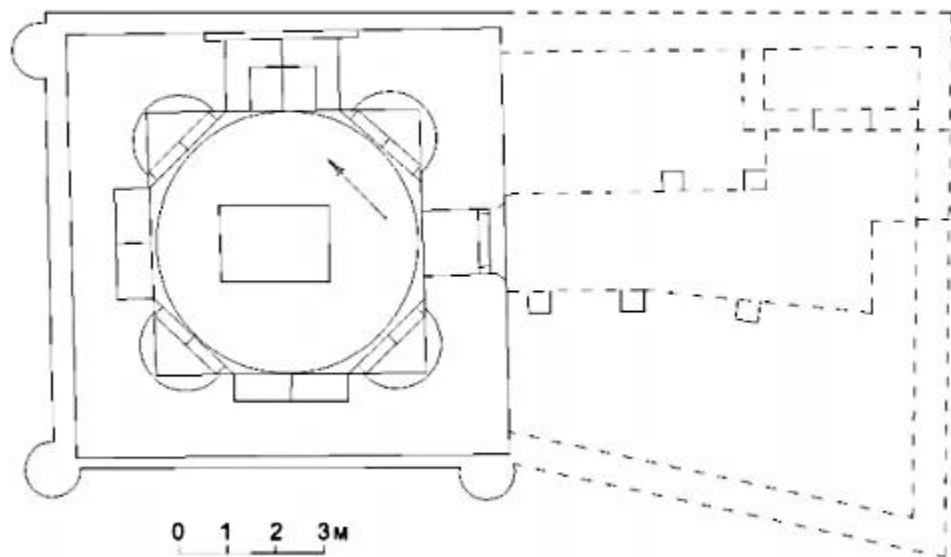





- Samarqand ,Timdagi Arab Ota maqbarasi

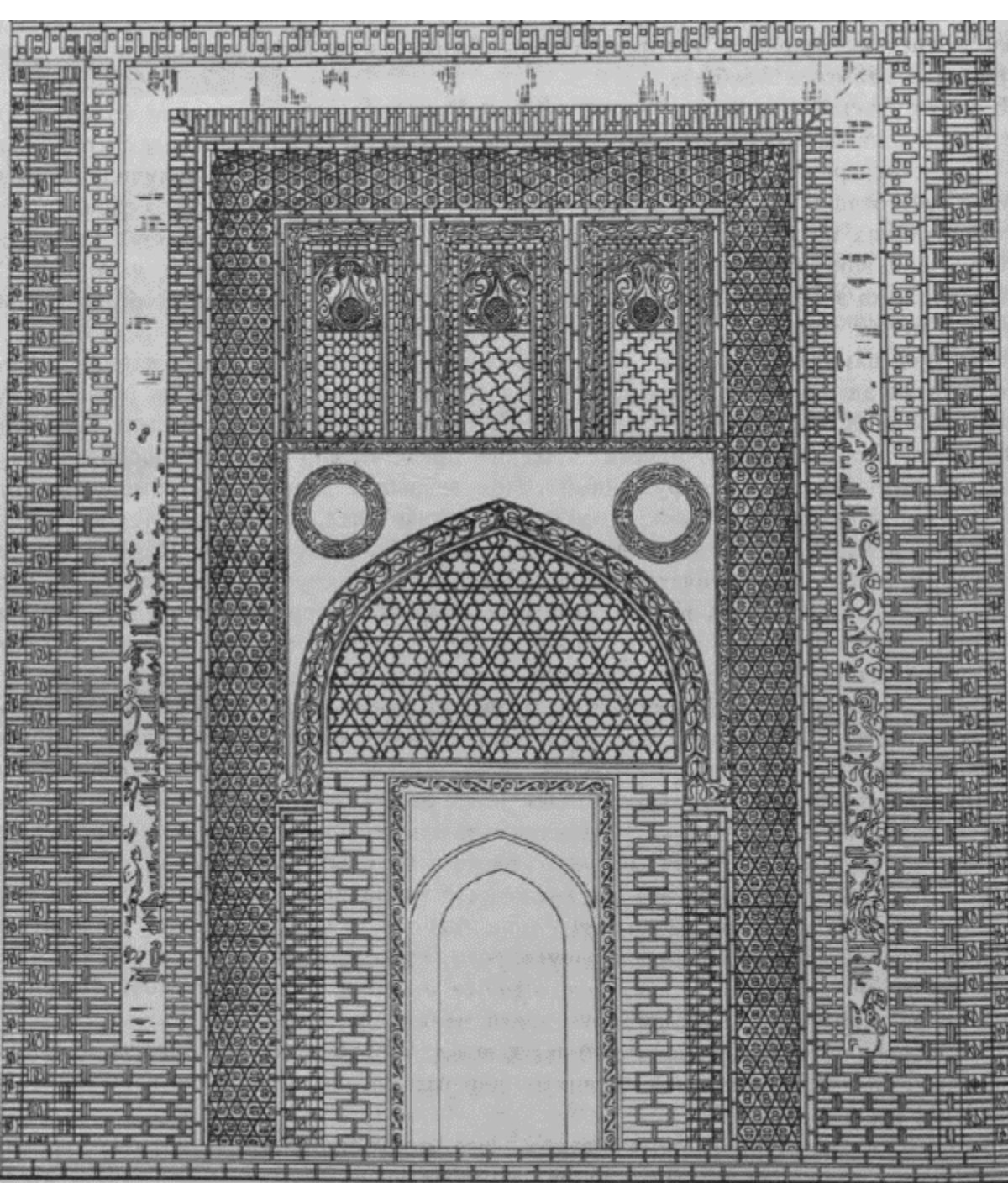

- Arab ota maqbarasining peshtoqi
- Samarqand, Tim
- 977-978 yillar



- Buxoro. Namozgoh masjidi (1119-1120 yy)
 - XII, XIV, XVII asrlar.

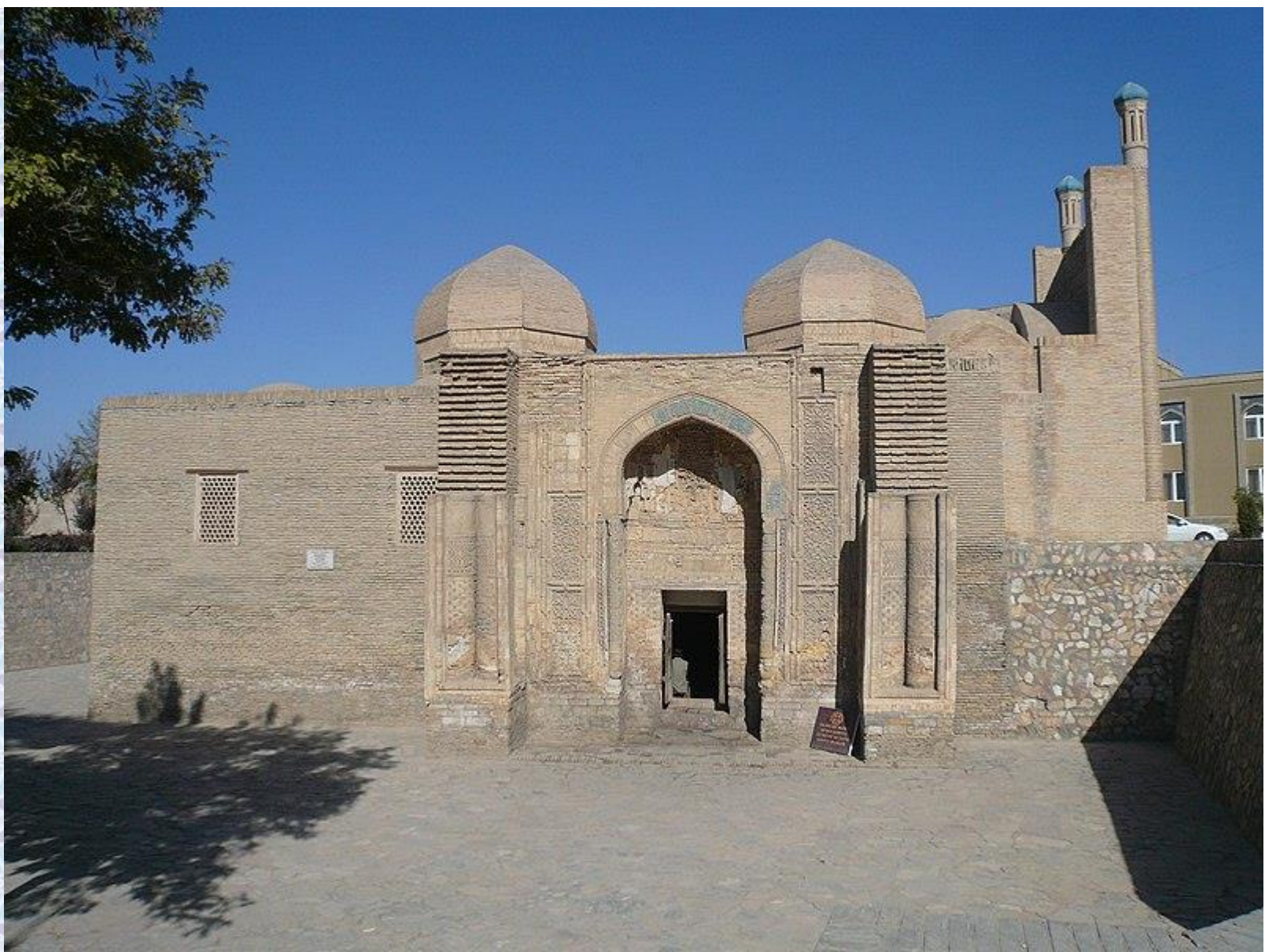

- Mag'oki Attor masjidi. X-XIV asrlar. YuNESKO ning umumjahon merosi. 602-ob'ekt

Diggaron masjidi





Султон Саодат мажмуаси. Термиз.





- Maliki Rabot karvonsaroyi. XI asr.





Sardoba Malik



- Rajab Xalifa maqbarasi. Qoraqalpog'iston. Mizdakxon majmuasi. 9-12 asrlar









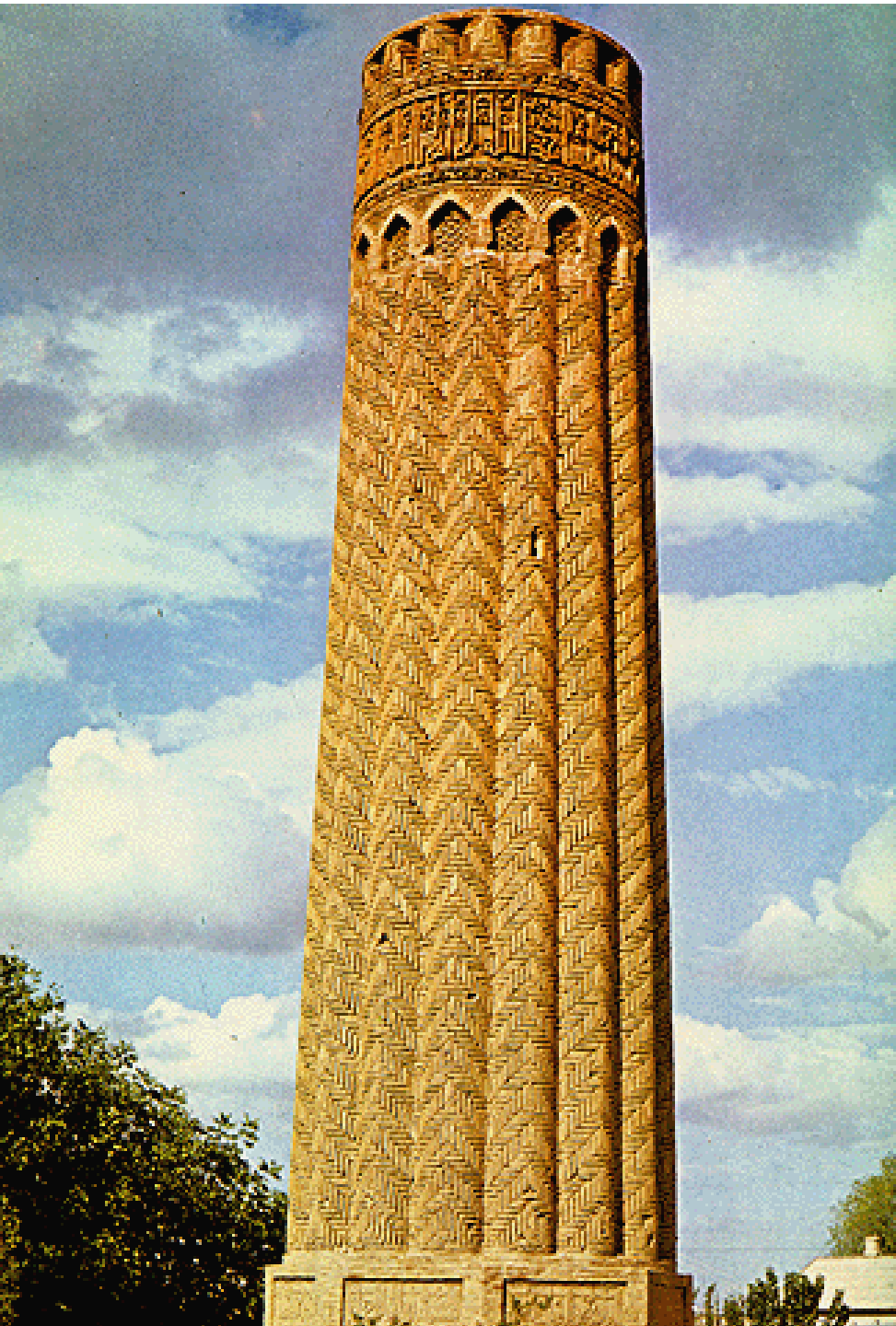

Jarqo'rg'on
minorasi.

Surxondaryo viloyati
Jarqo'rg'on tumani Minor
qishlog'i.

1108-09 yy.

Balandligi - 21,6 m.,
diametri – 5,4 m.

Me'mori- Ali ibn
Muhammad Saraxsiy.
Xuroson me'morchilik
maktabi an'analarida
bunyod etilgan.



All rights reserved
Copyright © www.CentralAsia-Travel.com

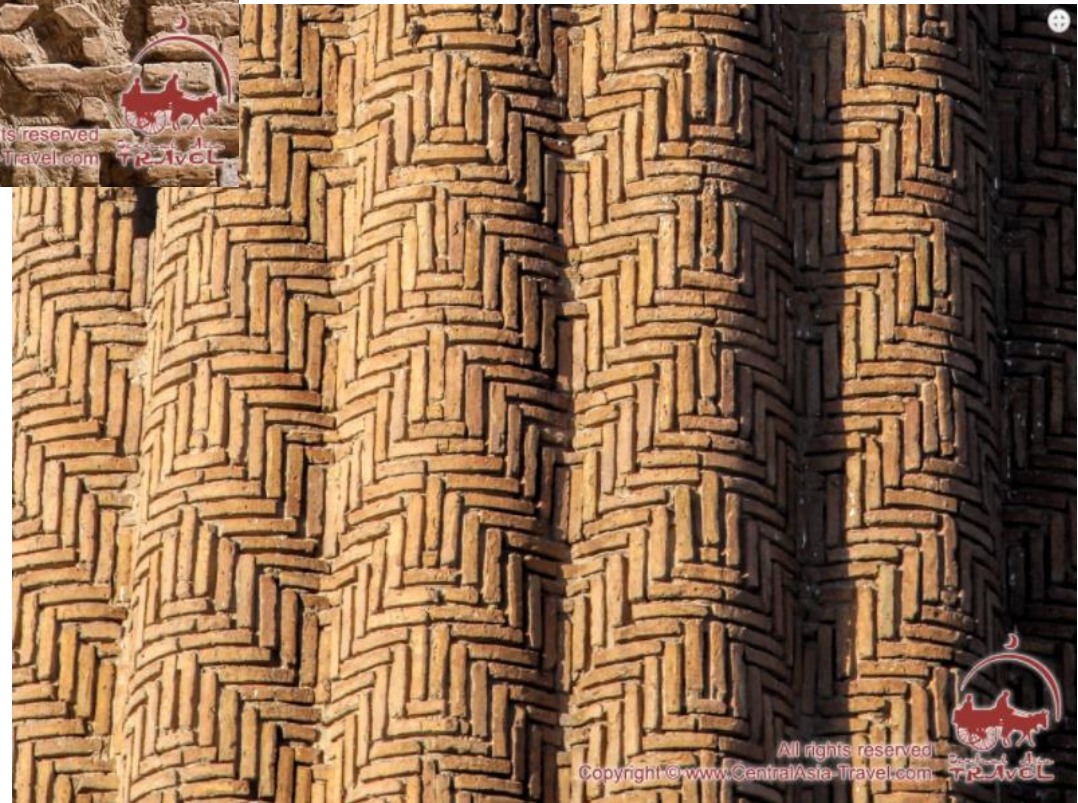

All rights reserved
Copyright © www.CentralAsia-Travel.com



- Вобкент минораси
- 1196—1198/1211 йй
- Меъмори- Sadr
Burhonidin Abdulaziz II

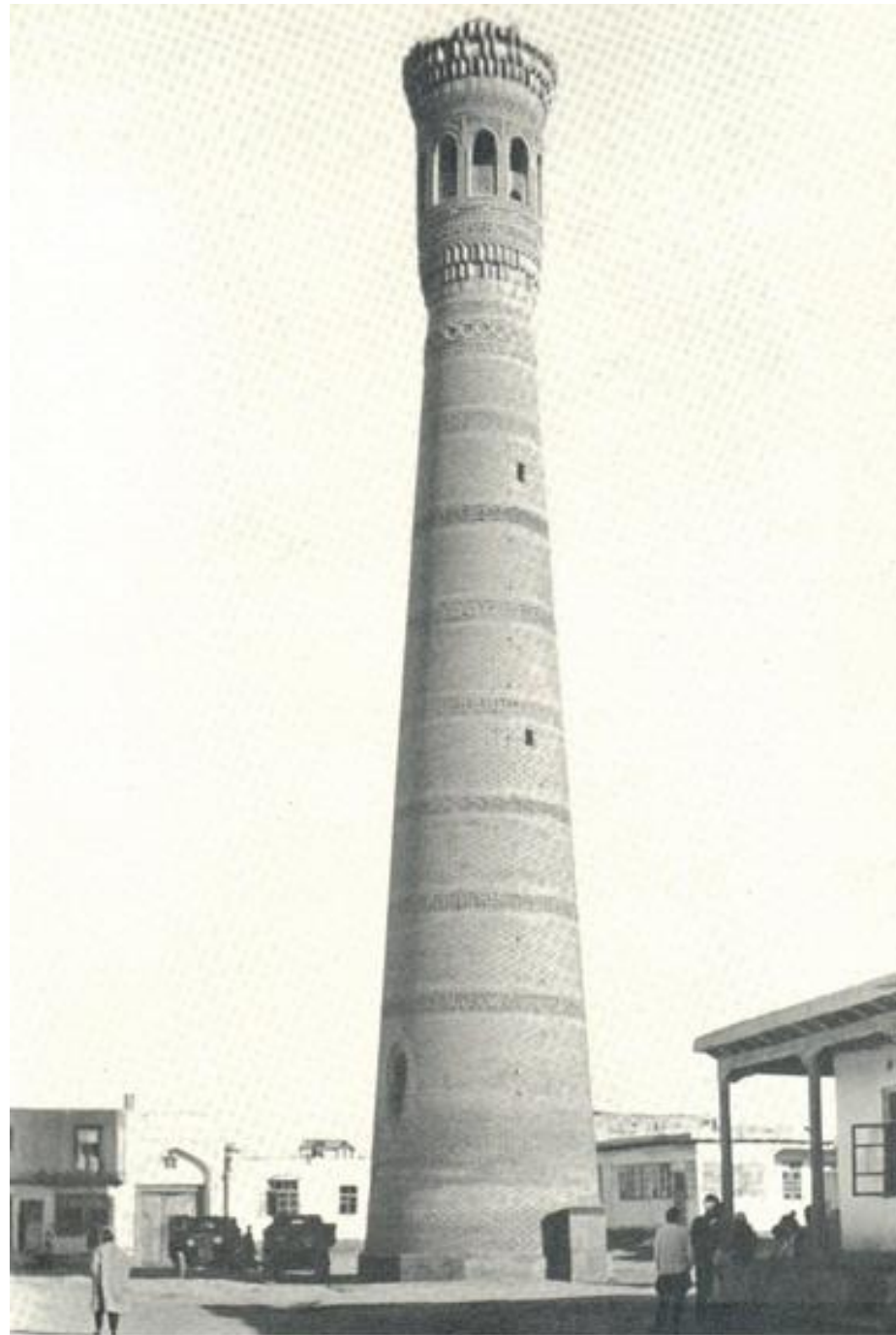

210. Минарети в Вобкенте, 1196—1198 э.э.

Buxoro.

Minorai Kalon. XII asr

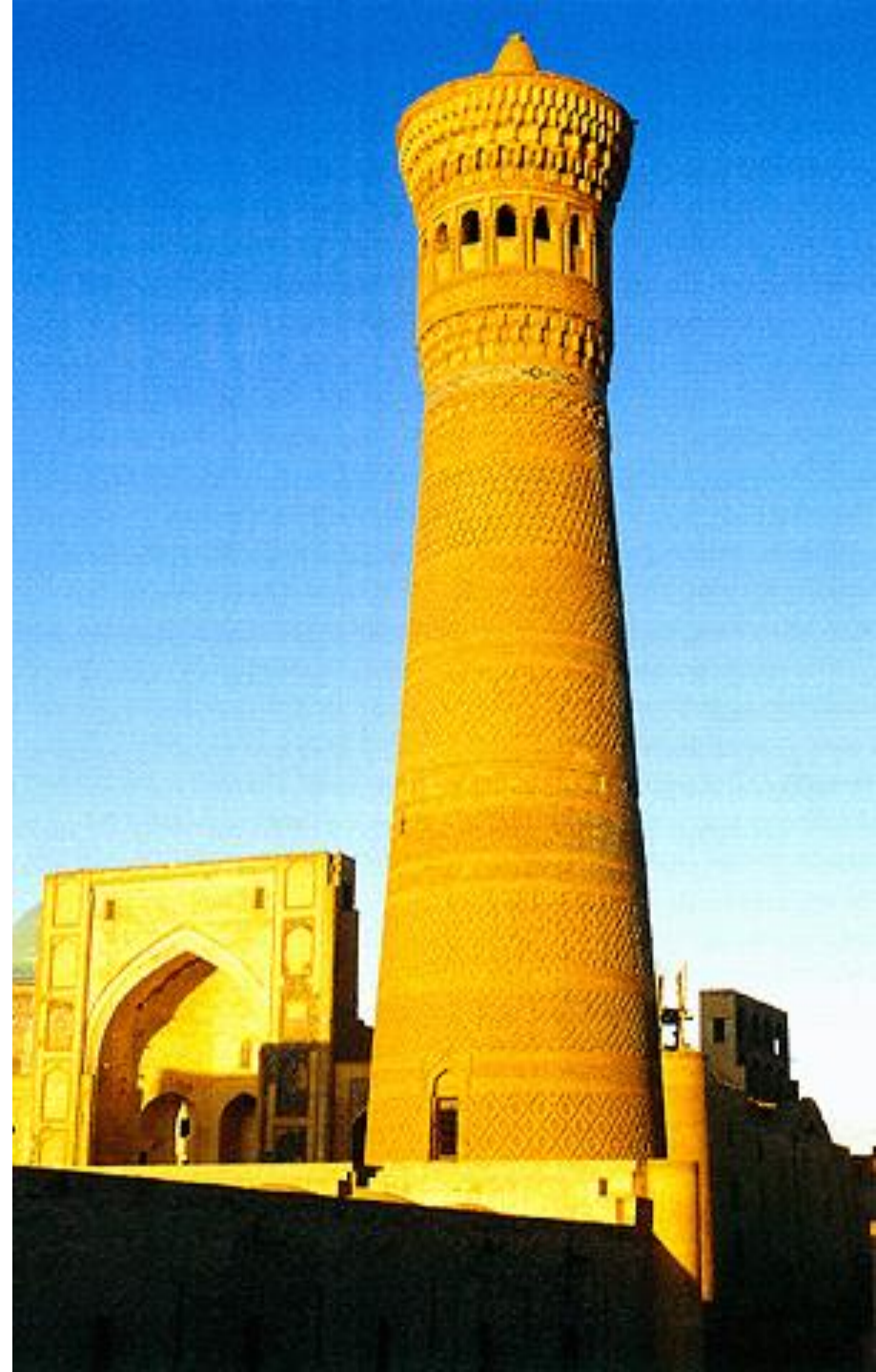







- Hakim at-Termiziy majmuasi. Masjid 12 asrga oid.



16/09/2011



- Самарқанд. Хожа Абду Дарун мақбараси. XII аср, XV асрнинг биринчи ярми.

Фахриддин Розий мақбараси



Кўҳна Урганч (Хоразм) даги Фахриддин Розий мақбараси ўзига хос хусусиятга эга. Гарчи у Ўрта Осиёда кенг тарқалган пештоқ-гумбазли композиция типига кирса ҳам, лекин у қиррали барабанга ўрнатилган чодирсимон гумбаздан ташкил топган.

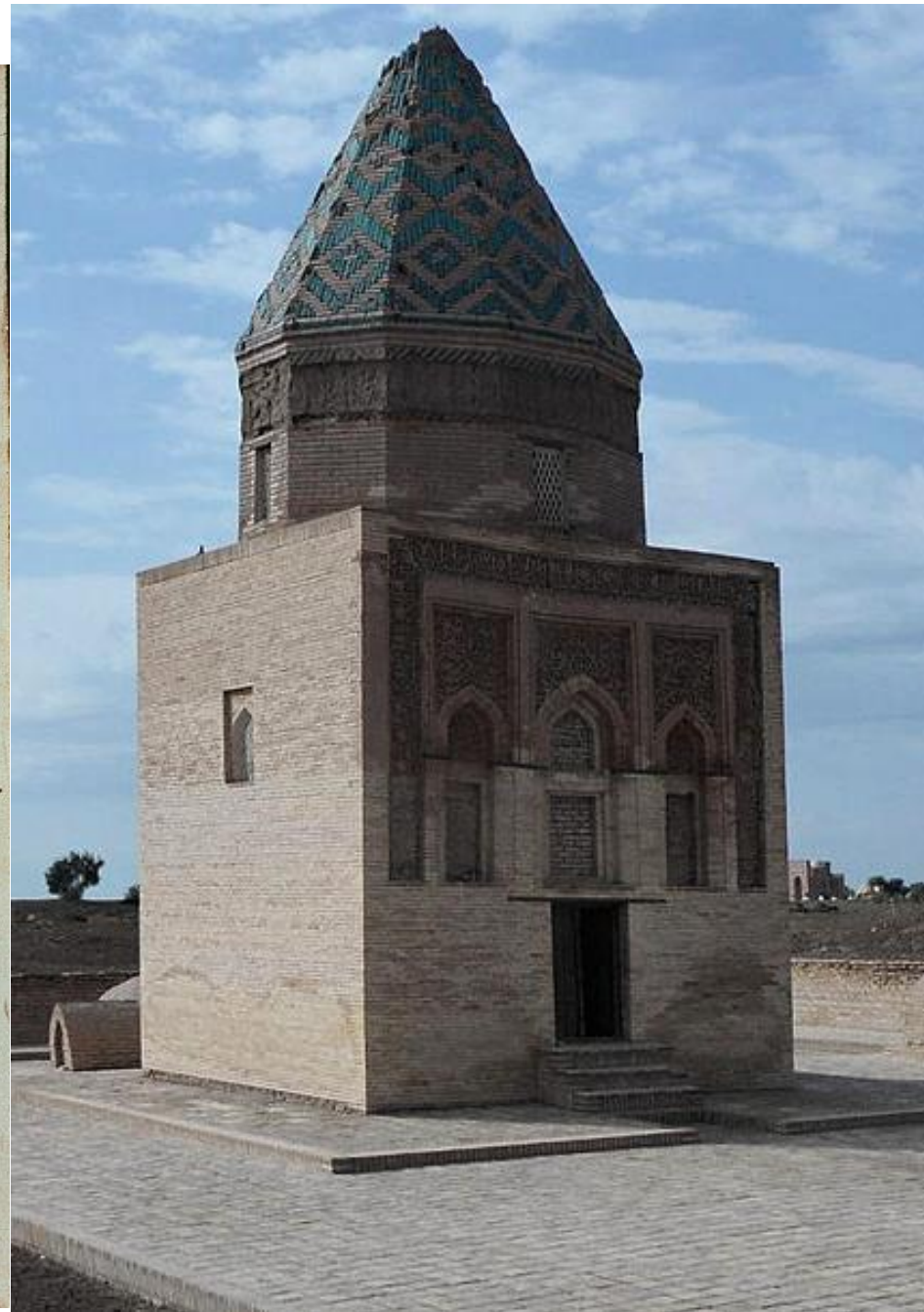
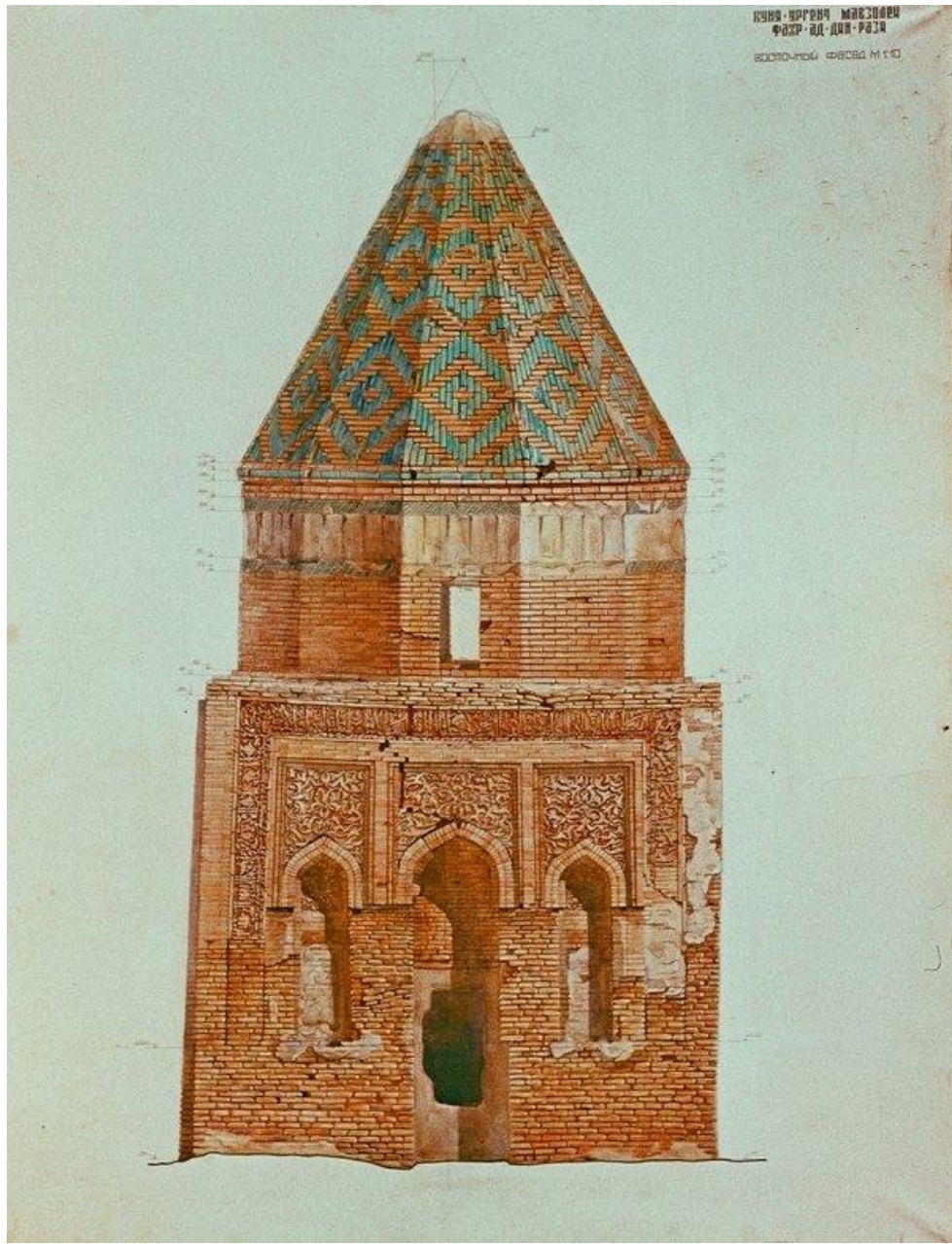

Нажмиддин Кубро мақбараси





Қутлуғ Темур
минораси. Қўхна
Урганч



Султон Такаш мақбараси





Сайфиддин
Бохарзий
мақбараси



Баёнқулихон мақбараси

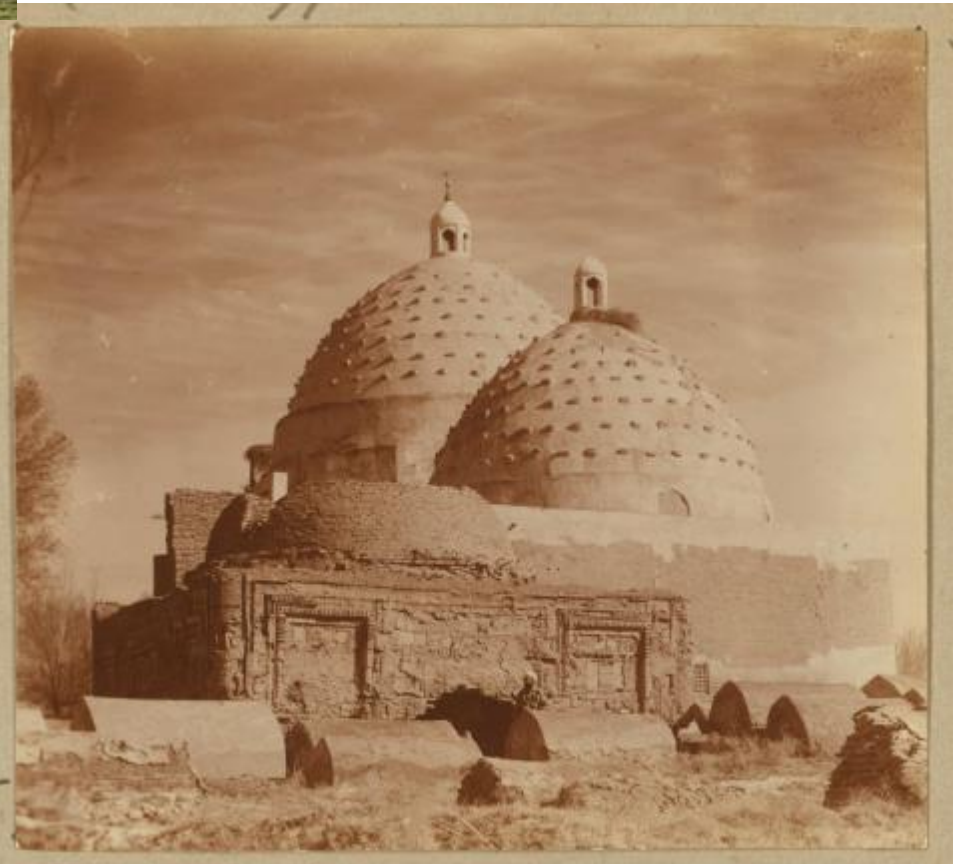
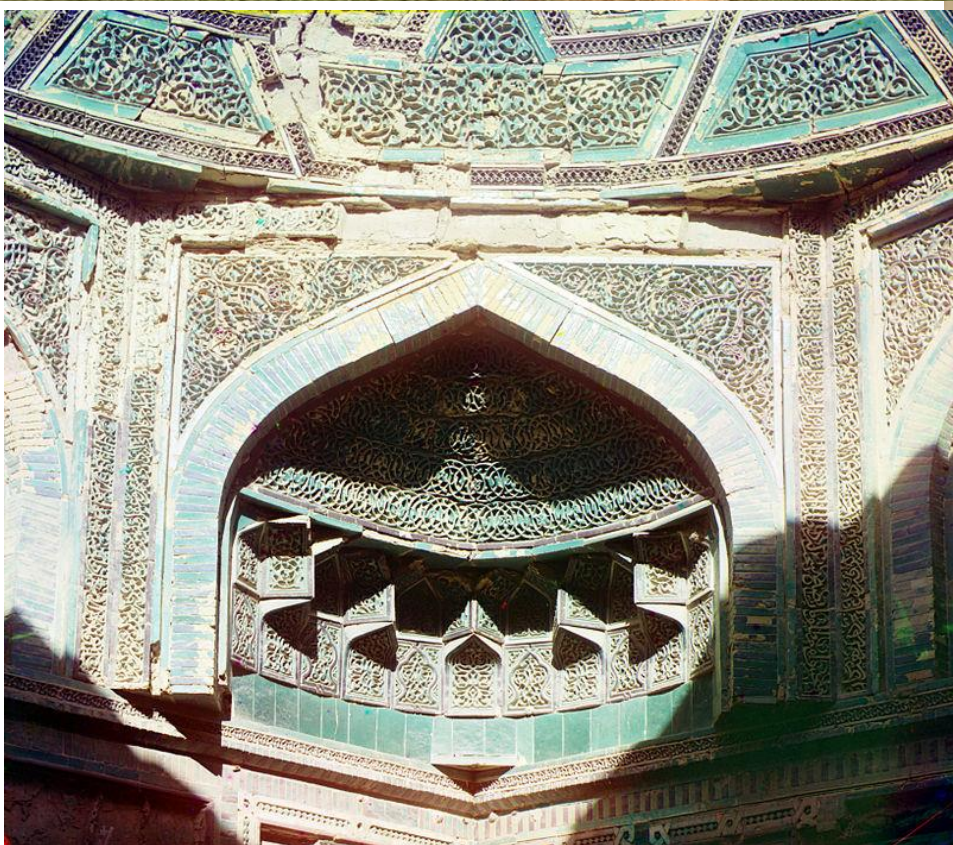



Тўрабекхоним мақбараси. 14 аср



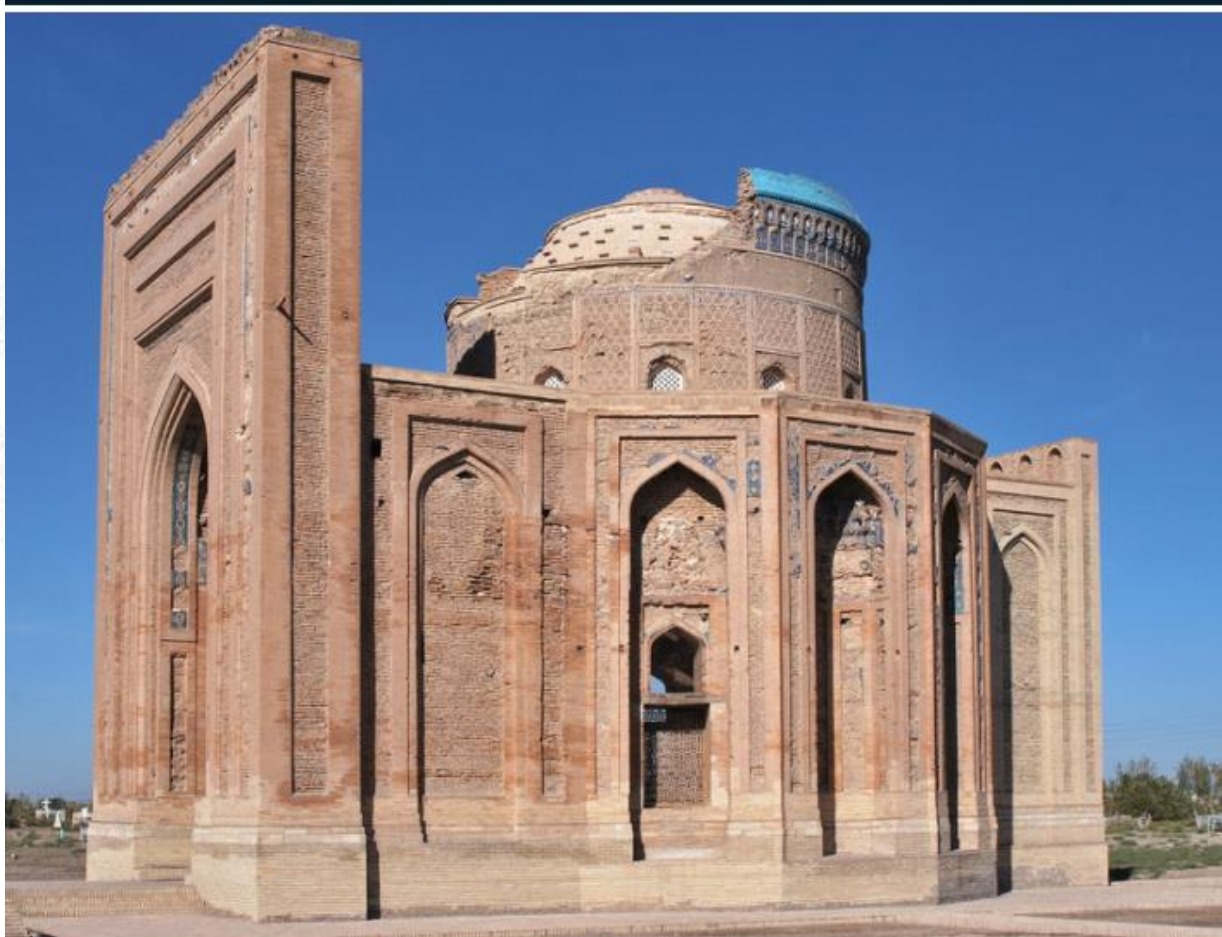
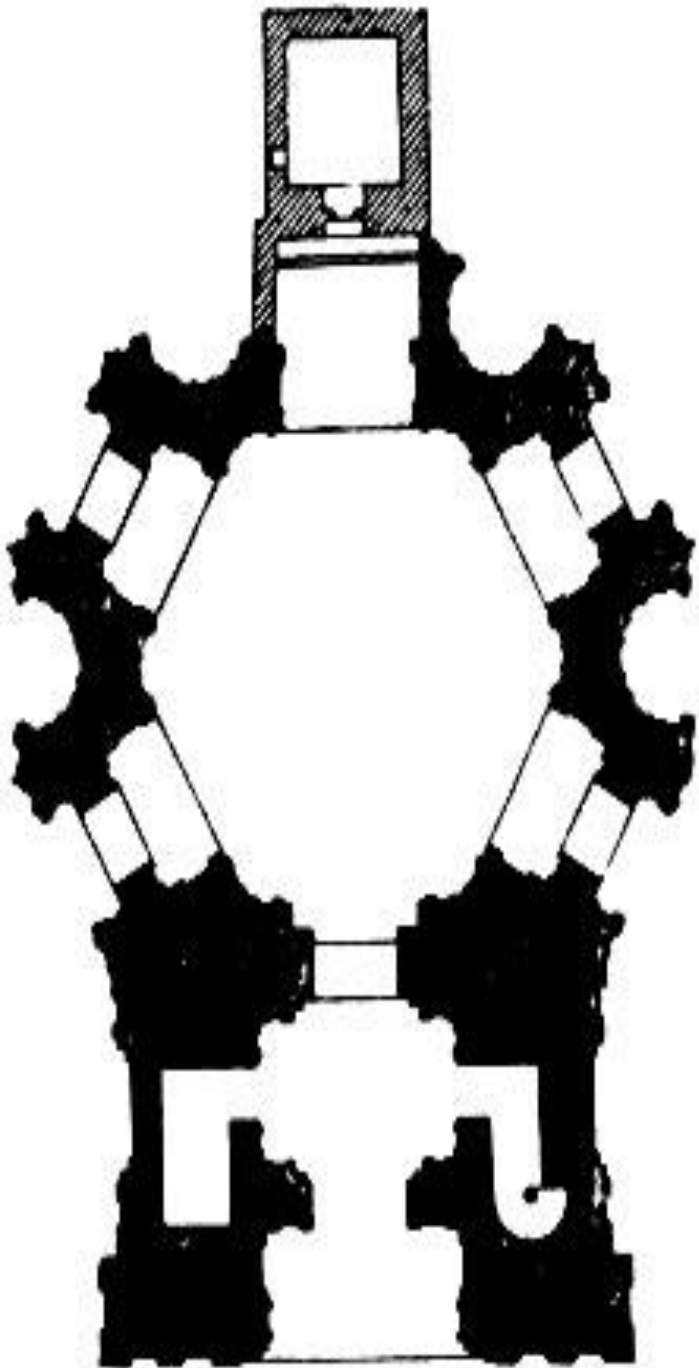





- Тўрабекхоним мақбараси кошинлари

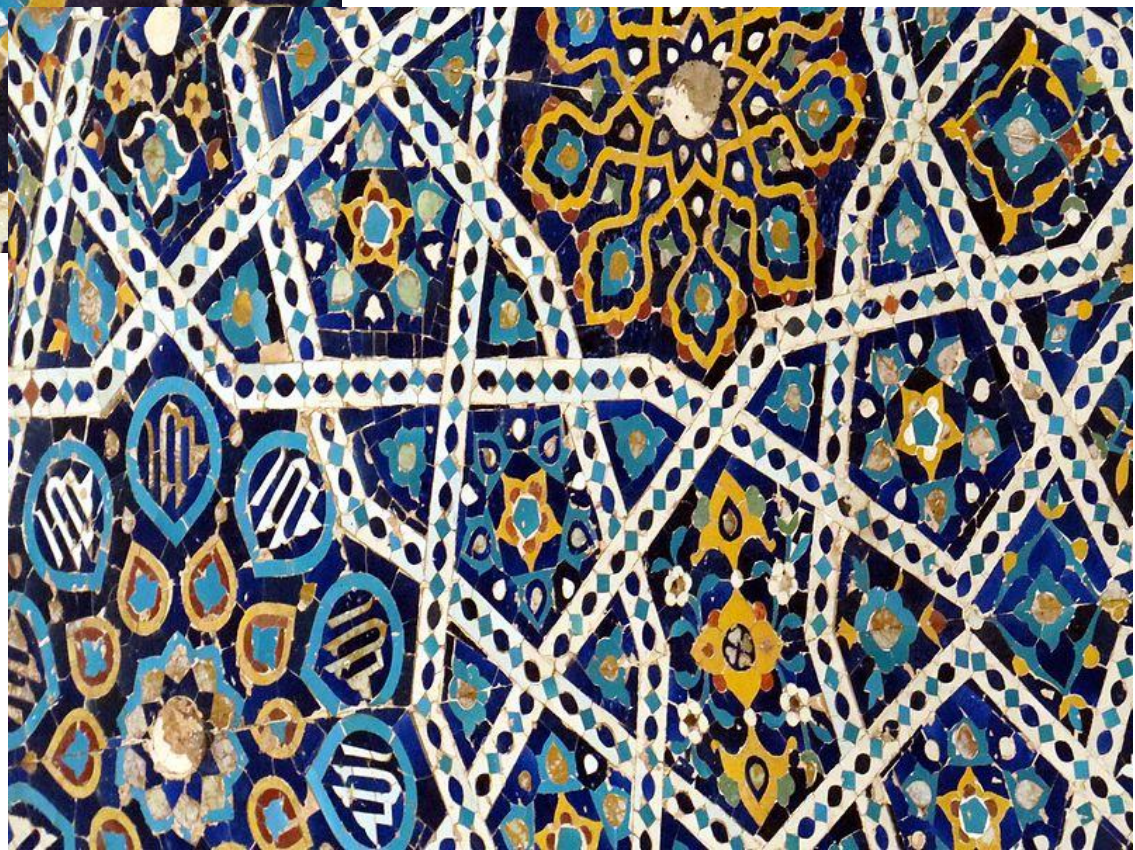

- Афросиёбнинг Қорахонийлар даврига оид суратлари (XII аср охирлари– XIII аср бошлар)







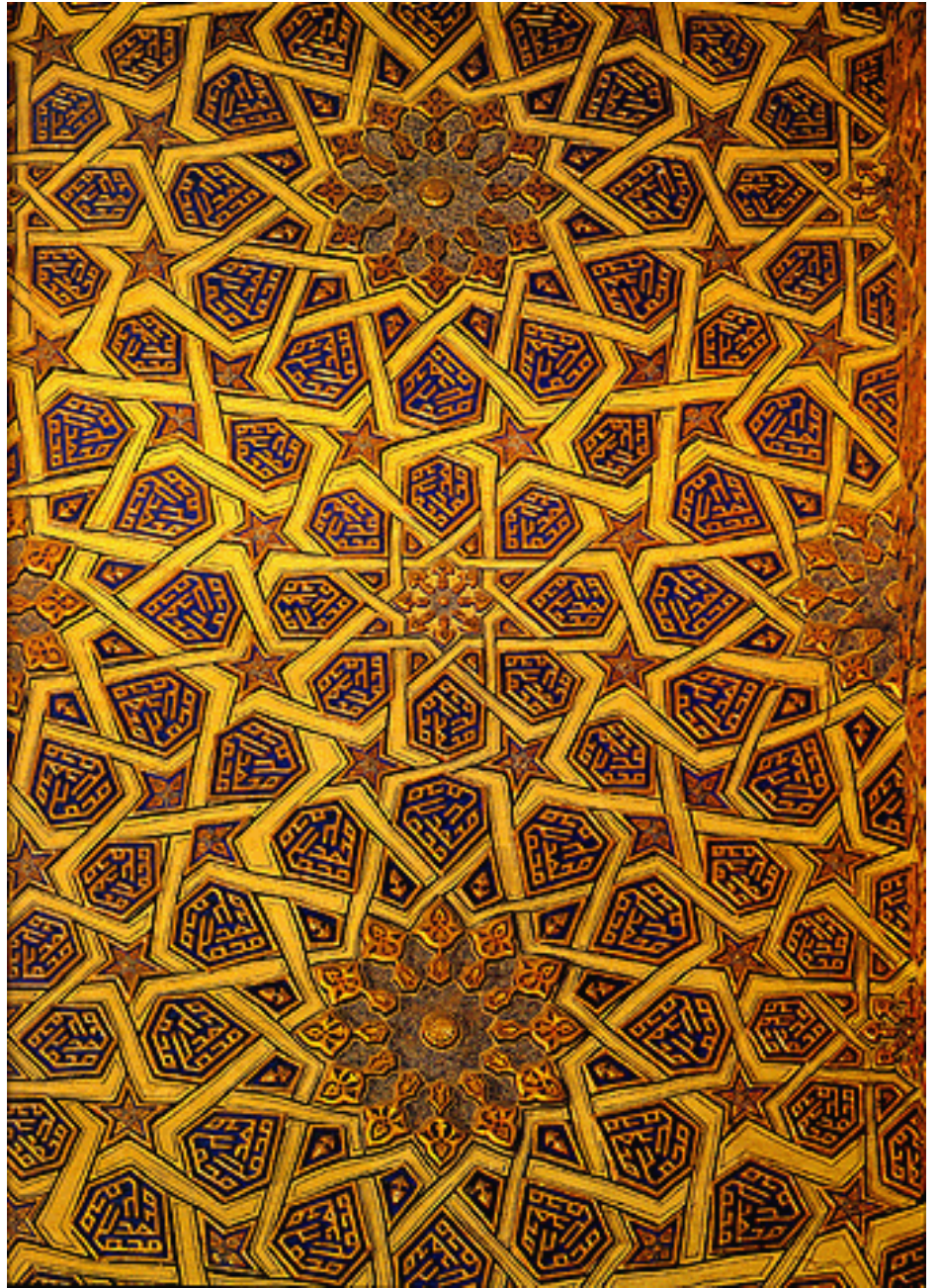

130. Кувшин с изображением красного верблюда. Серебро, VIII–IX вв.



- Қанотли туя тасвири туширилган идиш. Кумуш. 8-9 асрлар





Кумуш лаган
(Б.Маршак уни 10-
11 асрларга оид деб
ҳисоблайди ва
тасвирни Маҳмуд
Ғазнавий билан
боғлайди.



Қалай патнис (XI – XII
аа., Фарғона водийси).

Идиш тутган
“ҳукмдор”нинг юзи
туркий қиёфада, унинг
ҳолати эса Евроосиё
даштларидаги тош
ҳайкаллар -
болболларни эслатади.

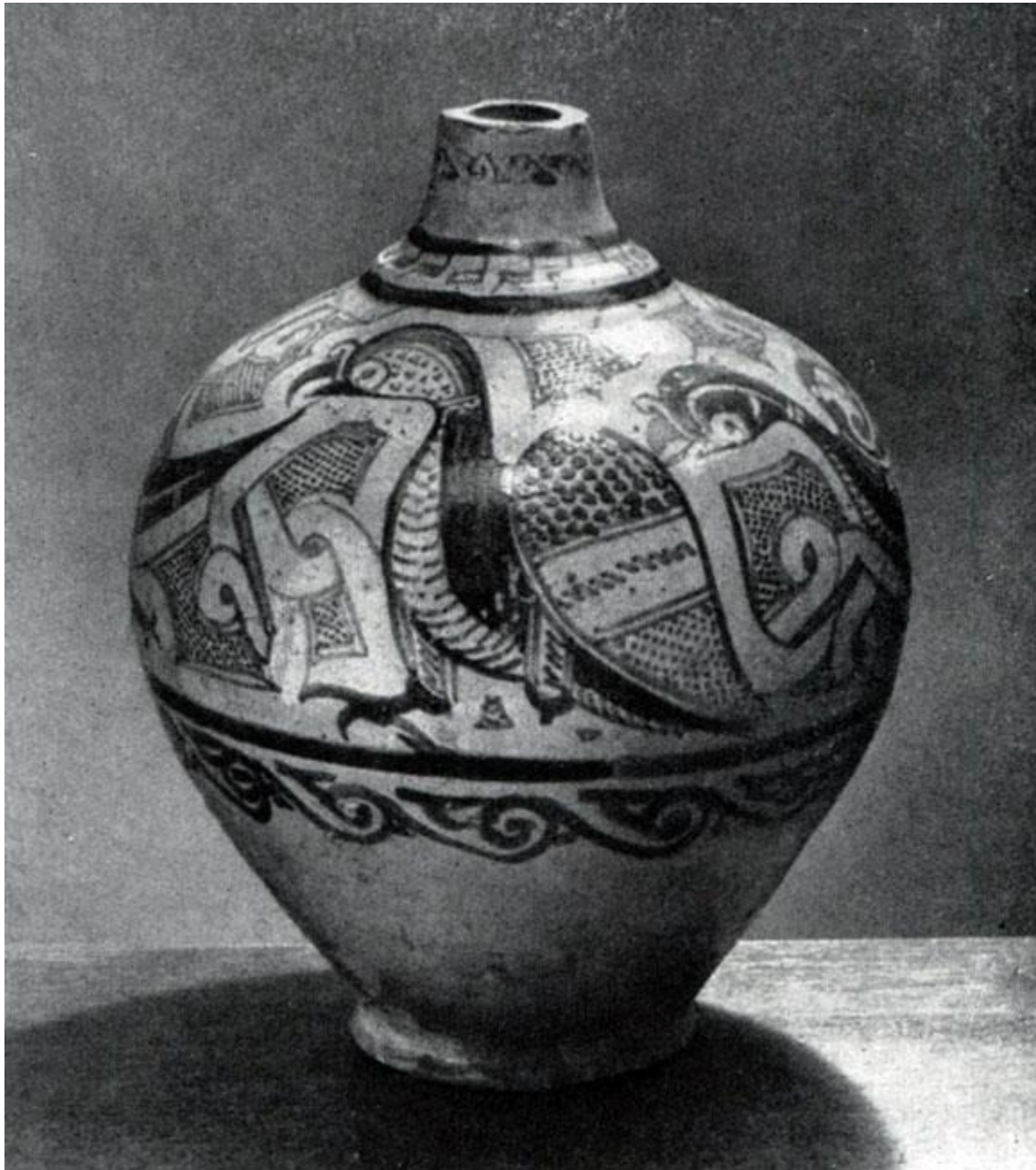

- Нақшли сопол
идиш. 10
аср.
Эрмитаж

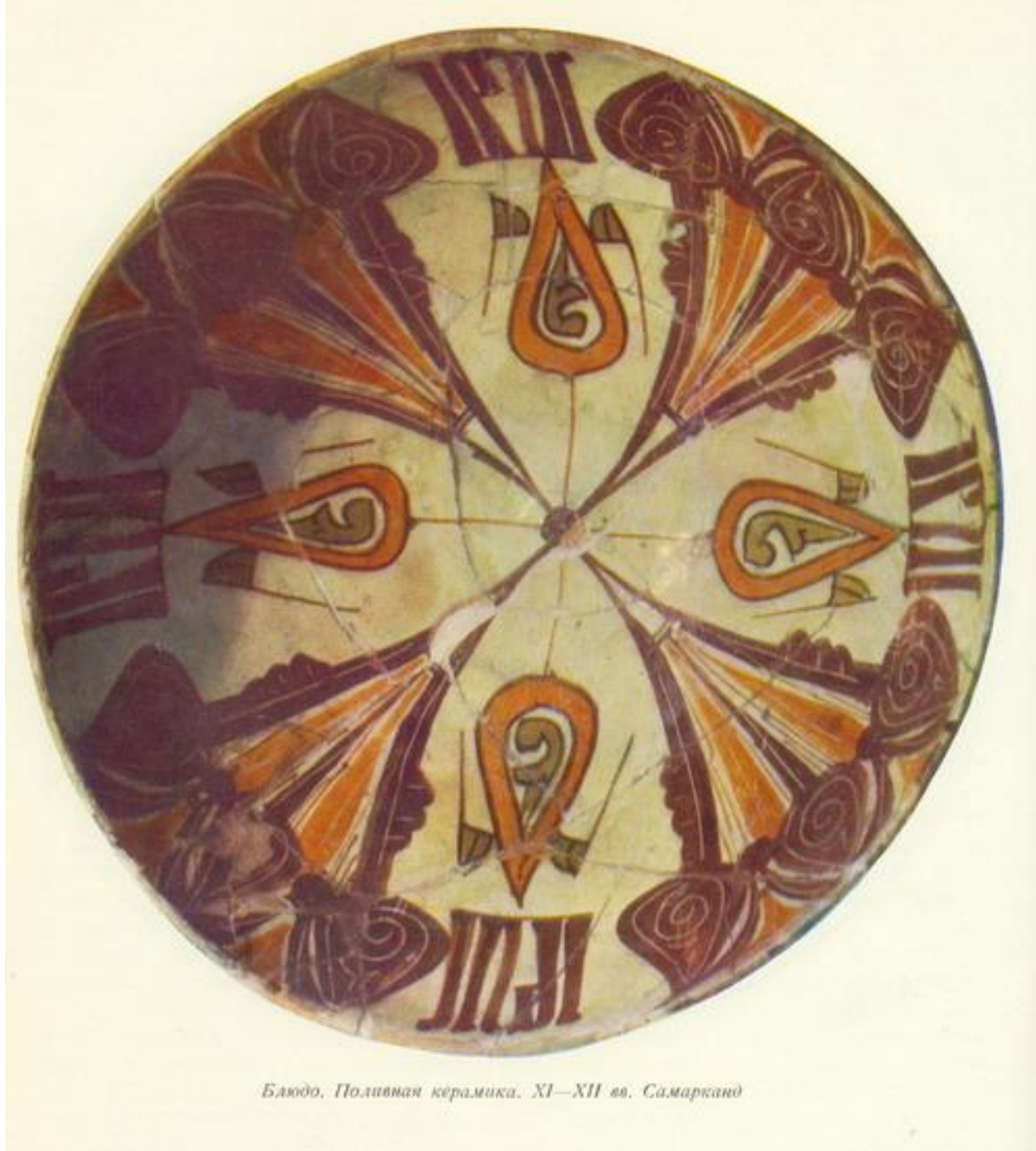

Блюдо. Поливная керамика. XI—XII вв. Самарканд

- Сирланган
идиш.
Самарқанд.
11-12 аср



- Афросиёб. Кулолчилик намунаси. IX-XII асрлар



Блюдо. Поливная керамика. X—XI вв. Самарканд

- Сирланган
идиш. 10-11
асрлар.
Самарқанд

Аёл қушлар. Сополдаги бўртма тасвир.
Самарқанд. 11-12 аср



223. Женщины-птицы. Рельефное изображение на керамике. XI—XII вв. Самарканд

Мушуксифат йиртқич тасвирланган сопол
тамға (XI – XII аа., Самарқанд. Самарқанд
музейи



Сирланган идиш, қанот ёзиб турган бургут тасвири, Самарқанд, XI – XII аа.



Ўрта асрлар кулолчилиги намуналари

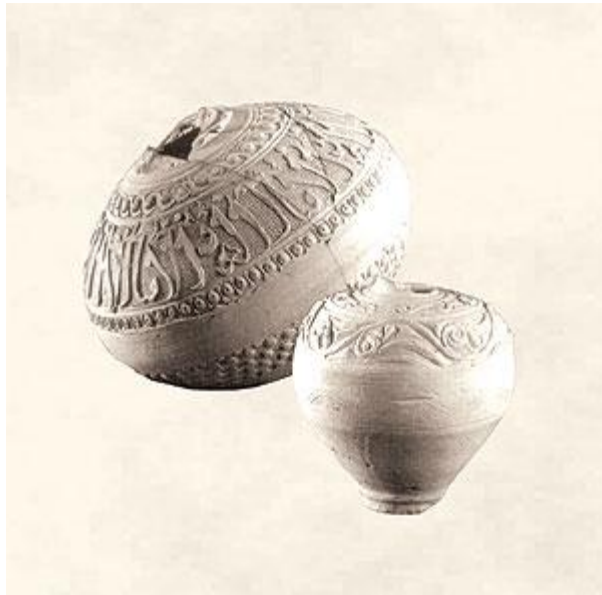

- Шишасозлик ва тоғ биллуридан буюмлар яшаш кенг ривожланган. 9-11 асрларга оид балиқ шаклидаги биллур идишча ва ҳайвон ёки одам боши шаклидаги пуфлаб ясалган шиша идишлар бунга мисол бўлади



11. Марханд

11. Таини Ошис-Ошиса, Самарканд



12. Мужики ошиса, Самарканд, 9-11 асрларга оид



- Шиша медальонларга босиб нақш солинган. Афросиёбдан топилган медальонга бош тасвири, Термиздаги ҳукмдор саройидан топилган 12 аср медальонига эса тожли ва қушли чавандоз, ов ва сарой саҳналари тасвири туширилган.

Ўзбек ёғоч ўймакорлиги





Мусхафи Усмон (644-656 й)

Мусхафи Усмон (644–656 й.лар).





- Xattotlik namunasi. Suls xati
- Eron. XVII a.
- Berlin davlat muzeyi

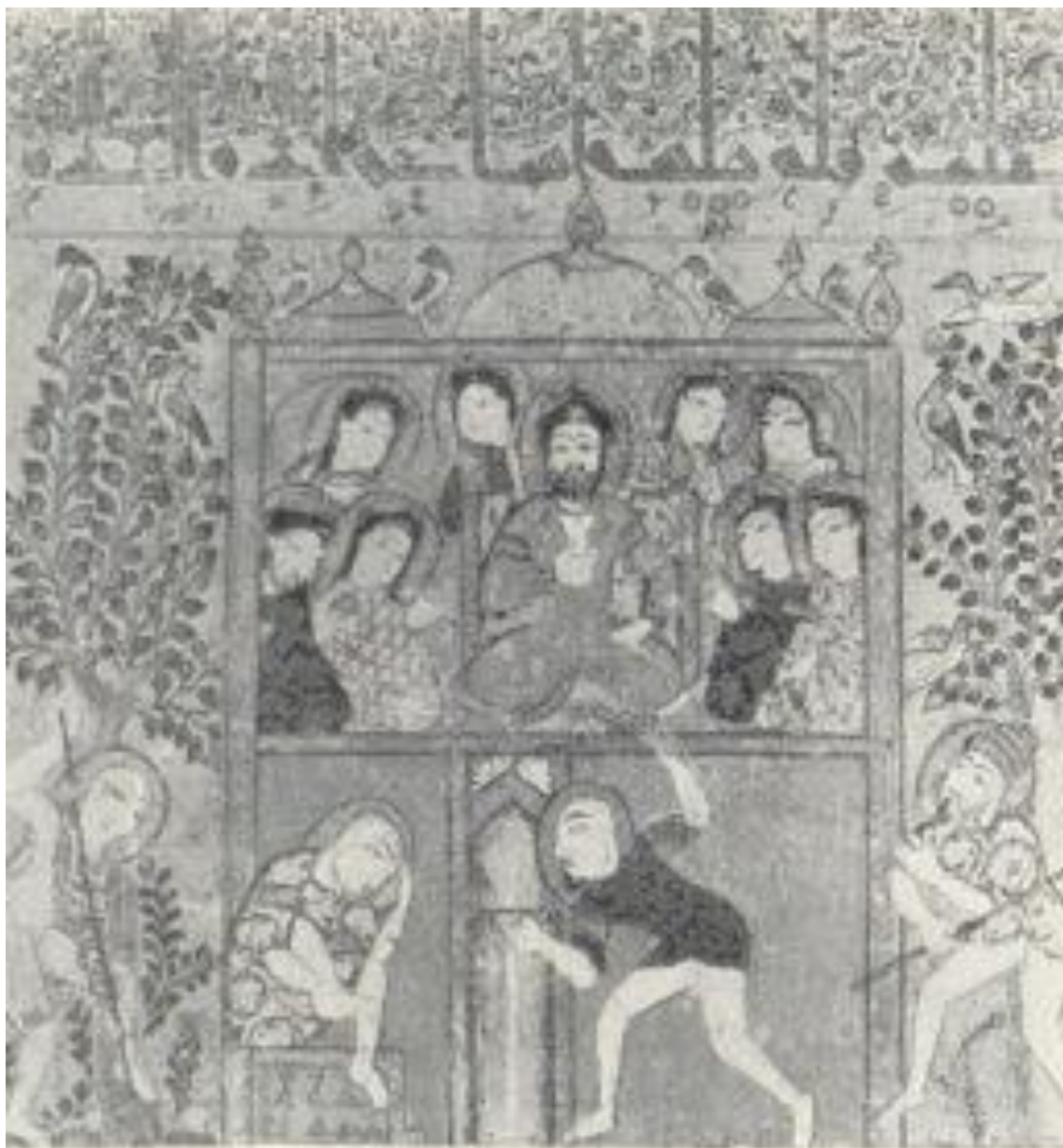

«Китоб ат –
Тирйак»
қўлёзмасидаги
миниатюра.
1199 й.
Париж
257х300

Ил. 16. Миниатюра из рукописи «Китоб ат-Тирйак». 1199 г.
Париж. Национальная библиотека.