

## 3-mavzu:

Ilk o'rta asrlarda O'rta Osiyo  
madaniyati va san'ati

# Adabiyotlar:

- Абдуллаев Н.У. Санъат тарихи Т.: “Ўқитувчи” 1987. 1-жилд
- Пугаченкова Г.А.Очерки искусства Средней Азии.– М.:Искусство, 1982.
- Пугаченкова Г.А., Ремпель Л.И. История искусства Узбекистана –М. 1985.
- Из истории живописи Средней Азии. Традиции и новаторство. –Т.1984.
- Г.А.Пугаченкова. Среднеазиатские миниатюры. –Т.: Шарқ. 1994.
- Азимов И. Ўзбекистон нақшу нигорлари. – Т.: Ғ. Ғулом номли адабиёти ва санъати нашриёти, 1987
- Ўзбекистоннинг янги тарихи. 1-3 жилдлар. Т.: “Шарқ”, 2000 -2004 йй.
- Ойдинов. Ўзбекистон тасвирий санъати тарихидан лавҳалар.–Т., Уқитувчи, 1997.
- [www.artuzb.narod.ru](http://www.artuzb.narod.ru).
- [www.architecture.uz](http://www.architecture.uz).
- [www.artmuseum.uz](http://www.artmuseum.uz).
- [www.sahnat.orexca.com](http://www.sahnat.orexca.com).
- [www.uzsanat.land.ru](http://www.uzsanat.land.ru).



Жужань

Хоразм

Сўғд

Маймурғ

Пойканд

Насаф

Куча

Қошғар

Хўтан

Нишопур

Марв

**Эфталийлар  
давлати**

Хирот

Қобул

Эрон



# Eftaliylar hukmdorlari tangalari







- Sosoniylar hukmdori Perozning tojini kiygan eftaliy podshosi. 5 asr oxiri.

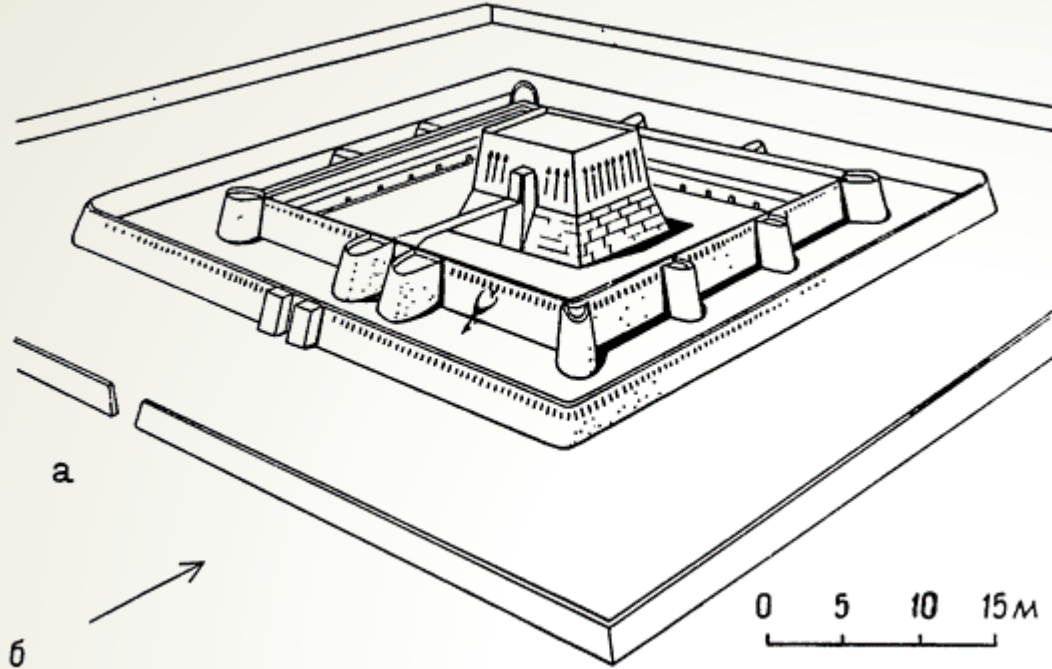

Xorazm.  
Yakkaparson  
(ilk o'rta asrlar.  
Rekonstruksiya)

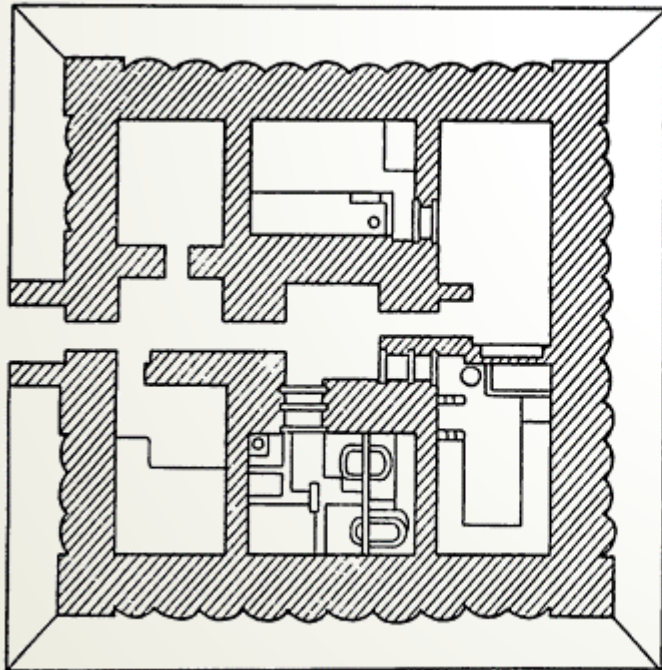



a

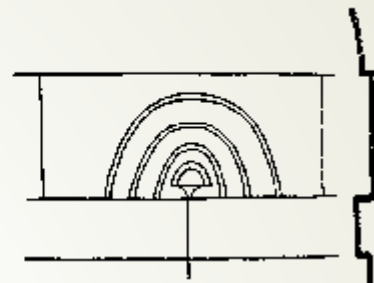
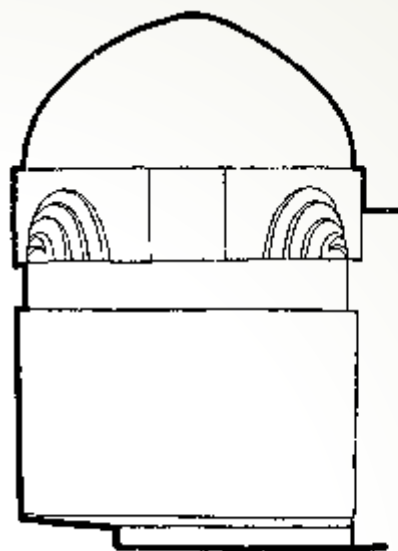
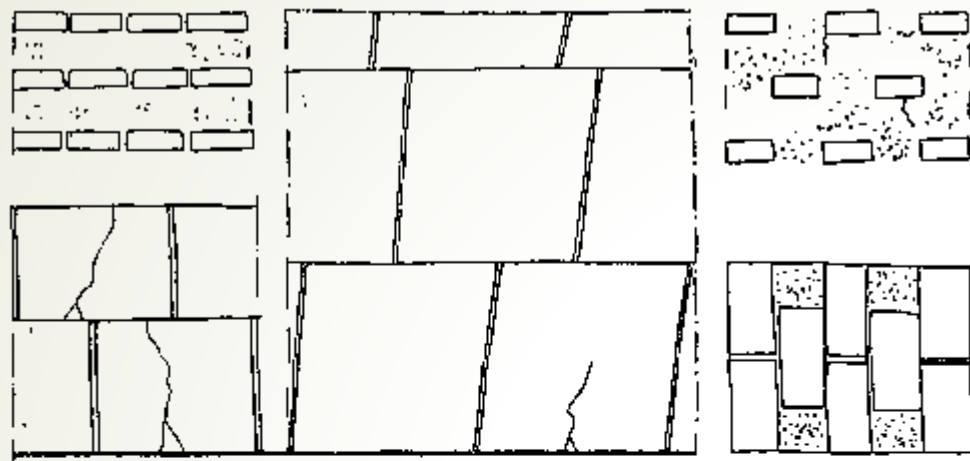

b

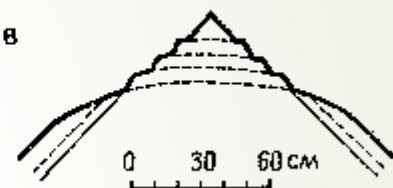

b

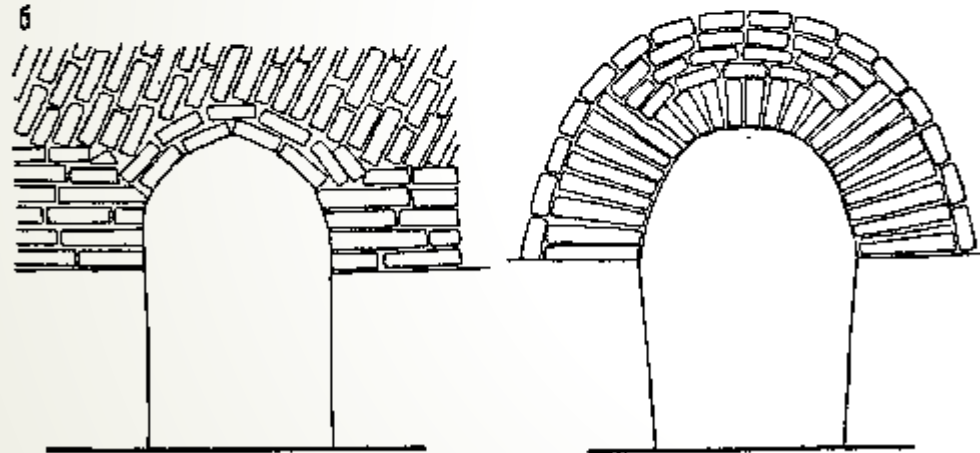

0 1 2 m

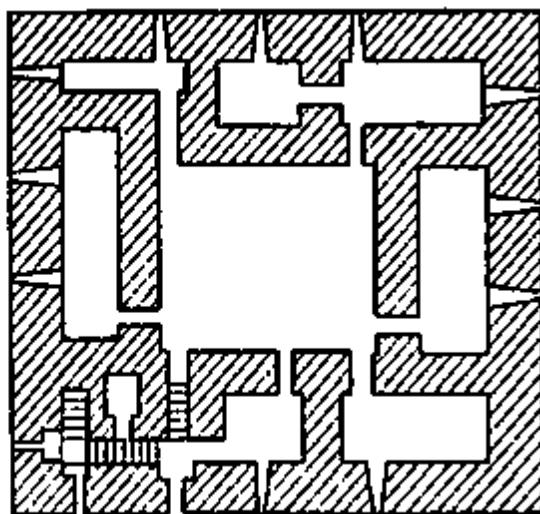
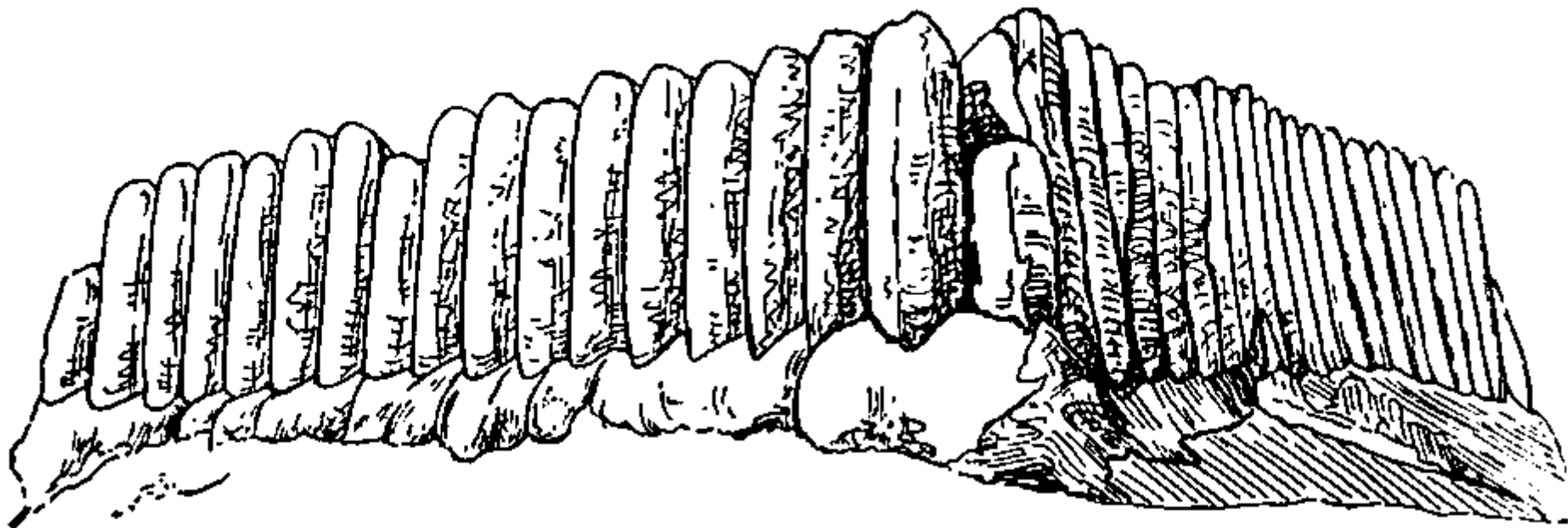

21M

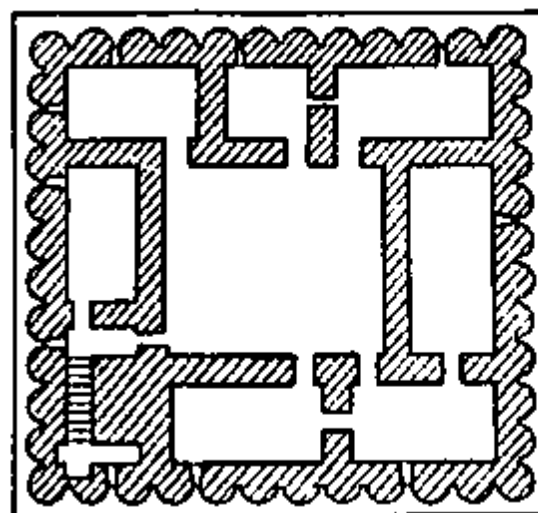

- Marv. Katta va Kichik Qizqal'a



# Xorazm. Ayozqal'a.



# Xorazm. Ayozqal'a.





# Poykent



# Poykent





# Poykent topilmalari





# Poykent topilmalari



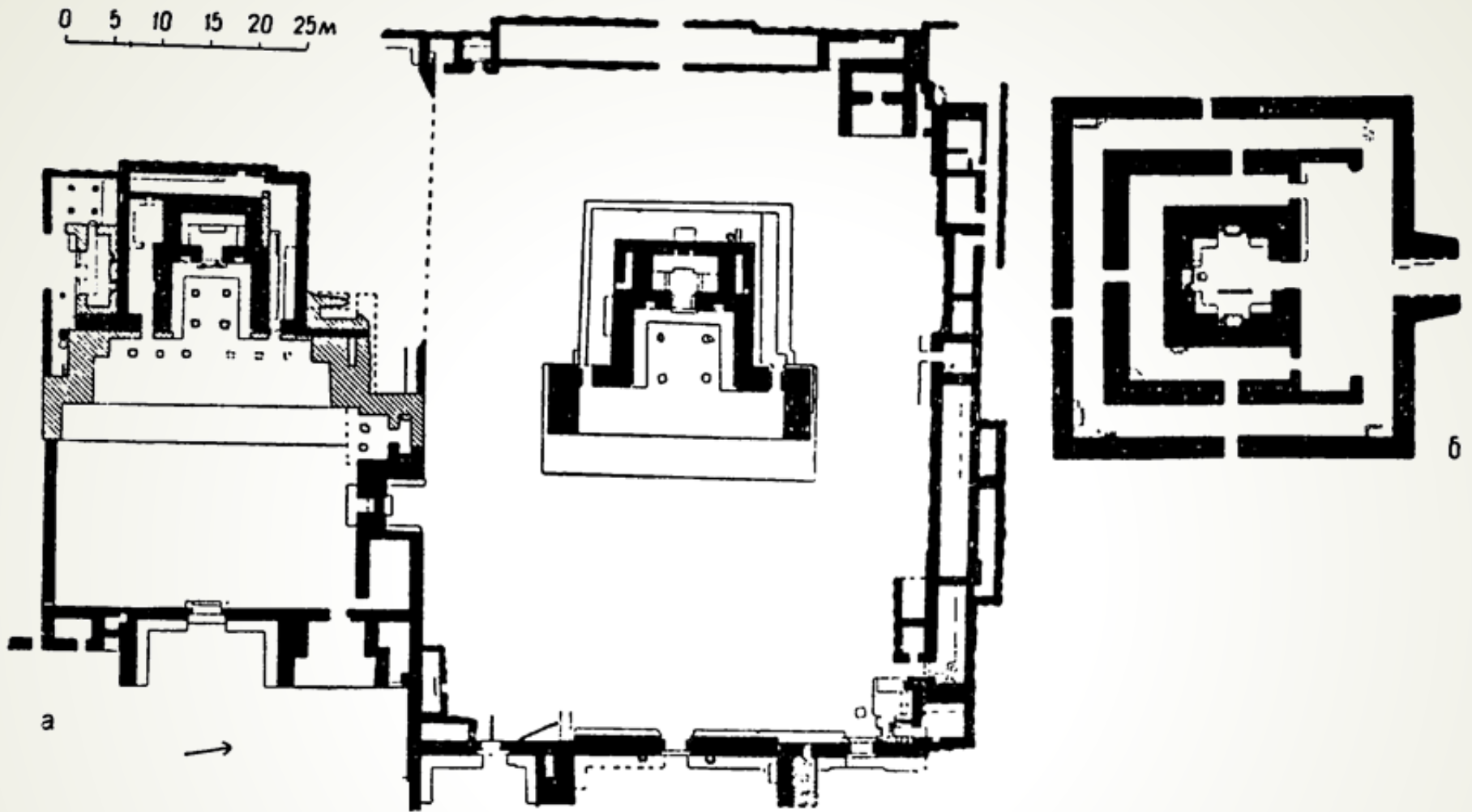

O'rta Osiyoning qadimgi ibodatxonalari:

- a) Qadimgi Panjikent ibodatxonasi
- b) Qirg'izistonning Oq-Beshimidagi budda ibodatxonasi





- «Eftaliylar kosasi», Pokiston hududi, 460-479 yy. Britaniya muzeyi.



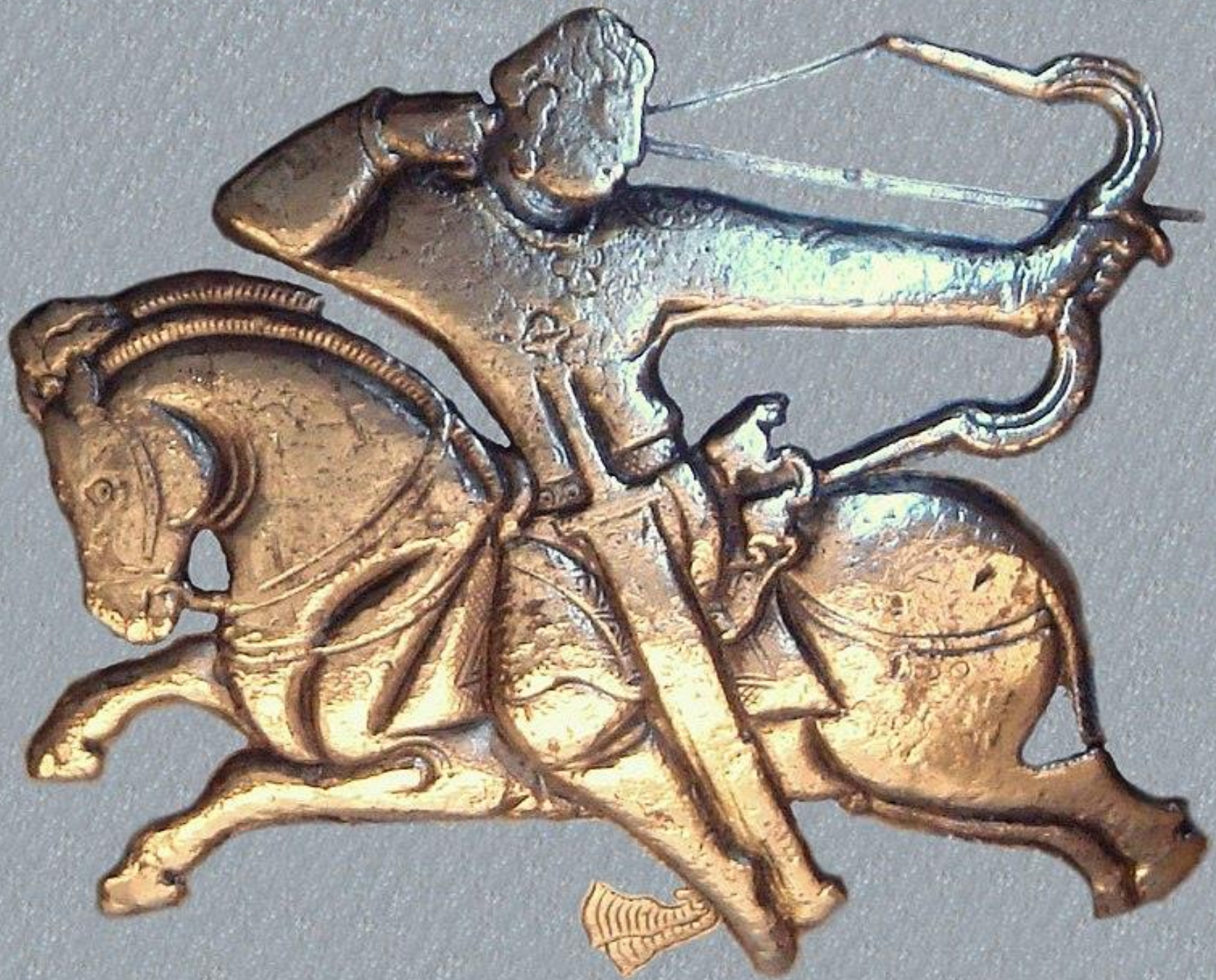





*Царь в окружении  
музыкантов и слуг.  
Рельеф на блюде.  
Сасанидский период*

- **1953-1954 yillarda** Surxondaryoda, Angor markazidan sharqiy tomonda qazib o'rganilgan **Bolaliktepa** qal'asi eftalitlar davrining diqqatga sazovor yodgorliklaridan biridir. Ilk o'rta asrlarda yirik mulkdor istiqomat etgan ko'shk bo'lgan.
- Bolaliktepa baland poydevor ustiga qurilgan ikki qavatli bino bo'lib, markazida bir-biri bilan bog'liq uchta zal va uning atrofida yo'laksimon xonalar joylashgan. Undagi zallardan birini ilk o'rta asrlarga xos zamindorlar ko'shkidagi bazm jarayoni aks ettirilgan devoriy suratlar bezab turgan. Bolaliktepa devoriy suratlari nainki Toxariston, balki butun bir Markaziy Osiyo xalqlarining ilk o'rta asrlar davri mahobatli san'ati tarixini o'rganishda muhim manba hisoblanadi.



■ Болаликт  
епа







Южная стена



- **Panjikent** xarobasini tekshirish **1946** yildan buyon olib borilmoqda. Tadqiqotlar natijasida V, VI, VII asrlarga oid bo'lgan turar joylar tekshirildi. Turar joylar jumlasiga **Divashtich saroyi**, boy va oddiy shahar aholisi uylari kiradi. Boy xonadon uylari murakkab reja asosida qurilgan. Bu yerda ham ijtimoiy uylar, 2 ta ibodatxona ochib o'rganildi.



# Panjikent (VI—VIII asrlar)

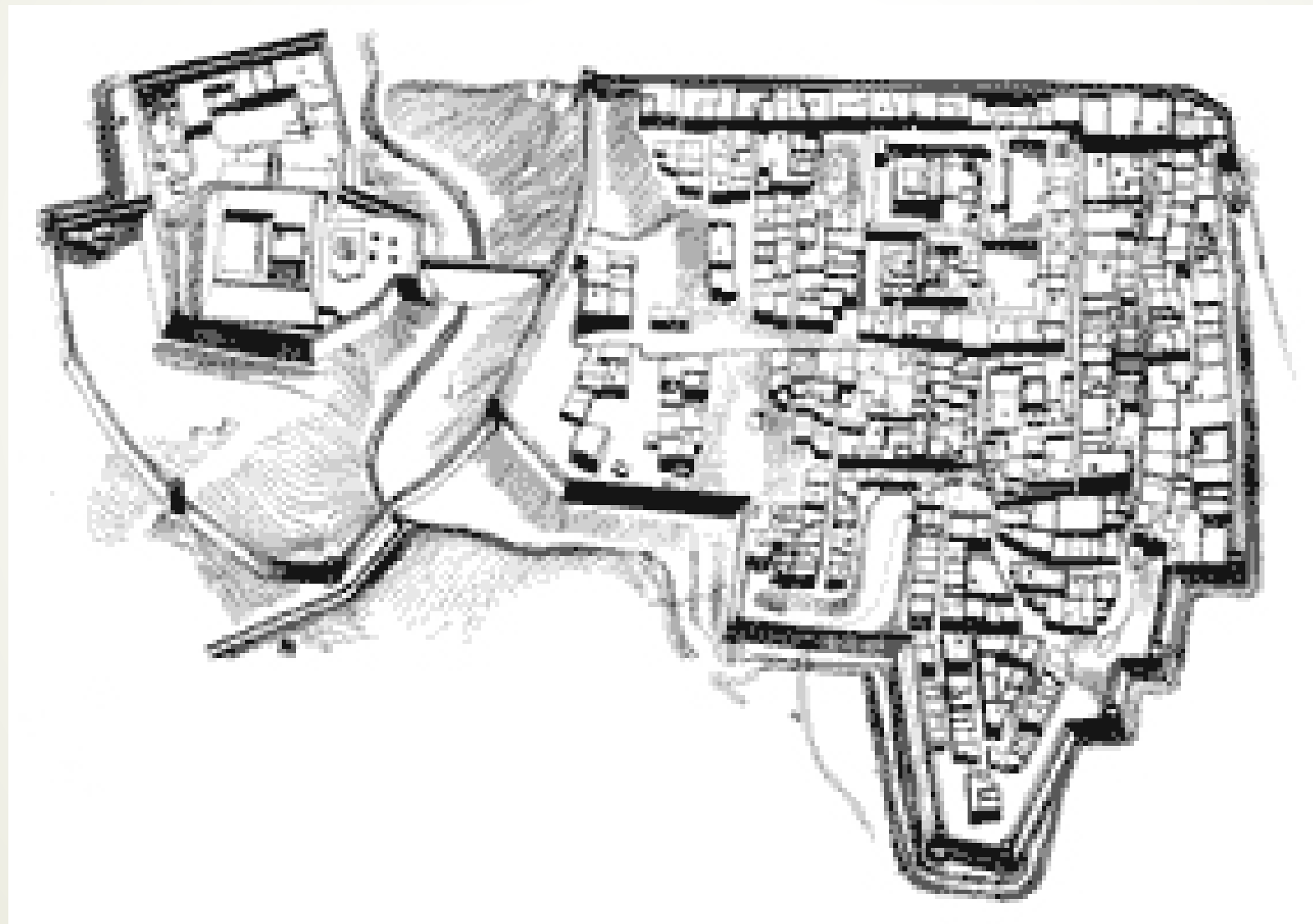

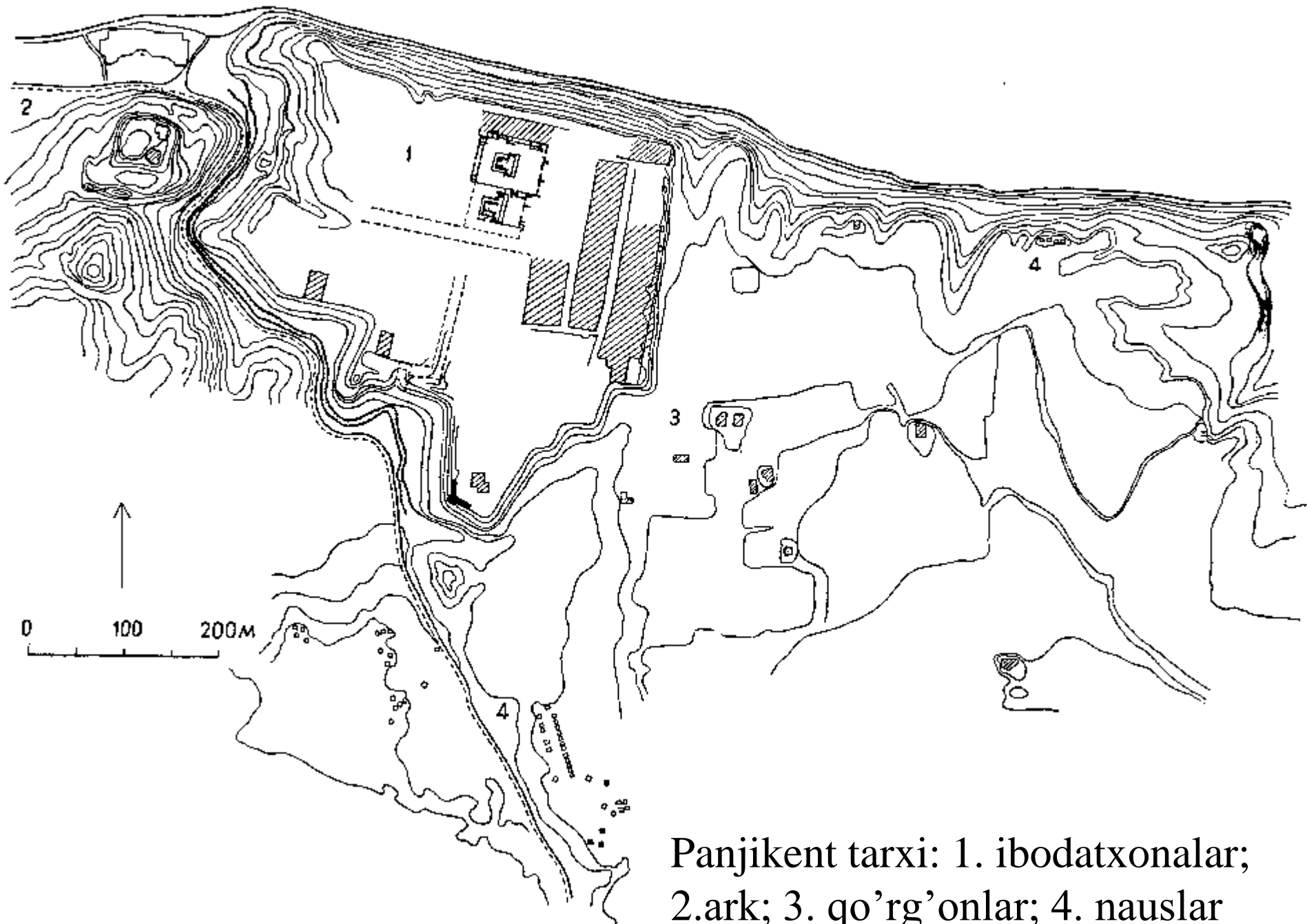

Panjikent tarxi: 1. ibodatxonalar;  
2.ark; 3. qo'rg'onlar; 4. nauslar



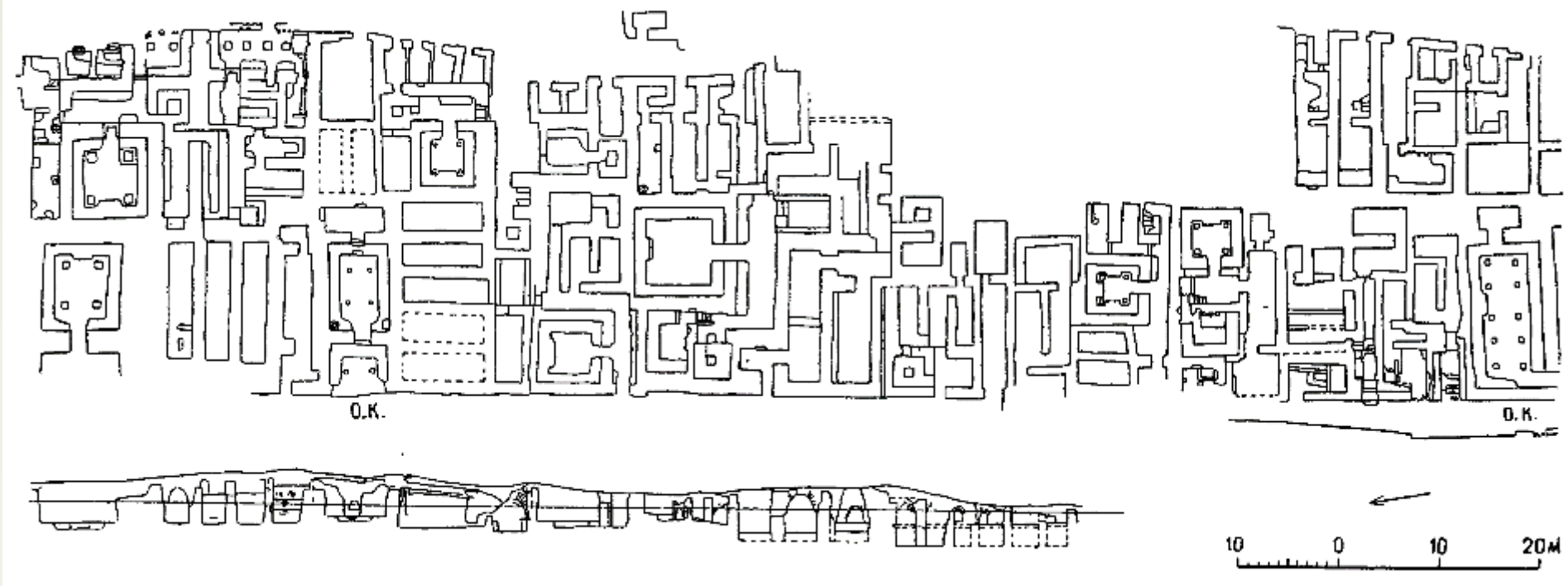

Panjikent. Shahrstonning sharqiy qismidagi turar joy. Tarx, kesim.

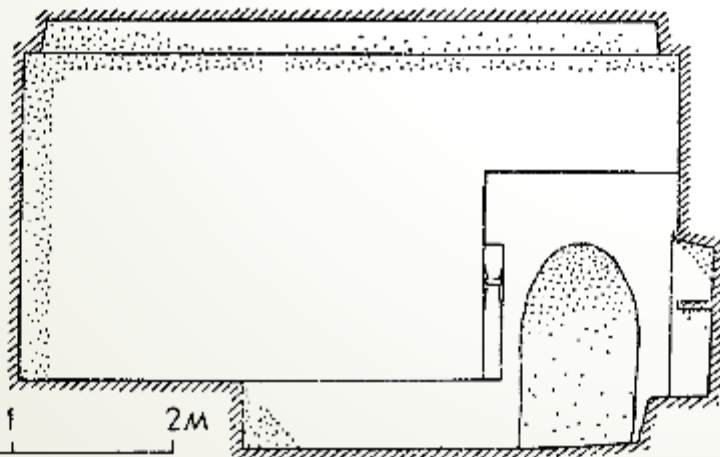
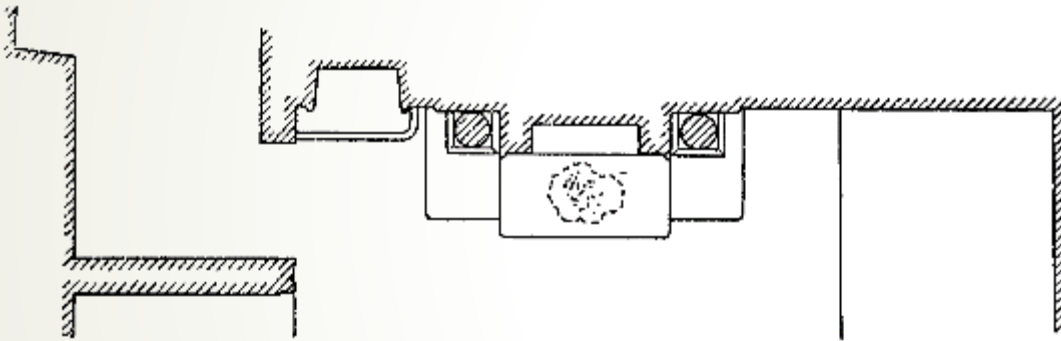
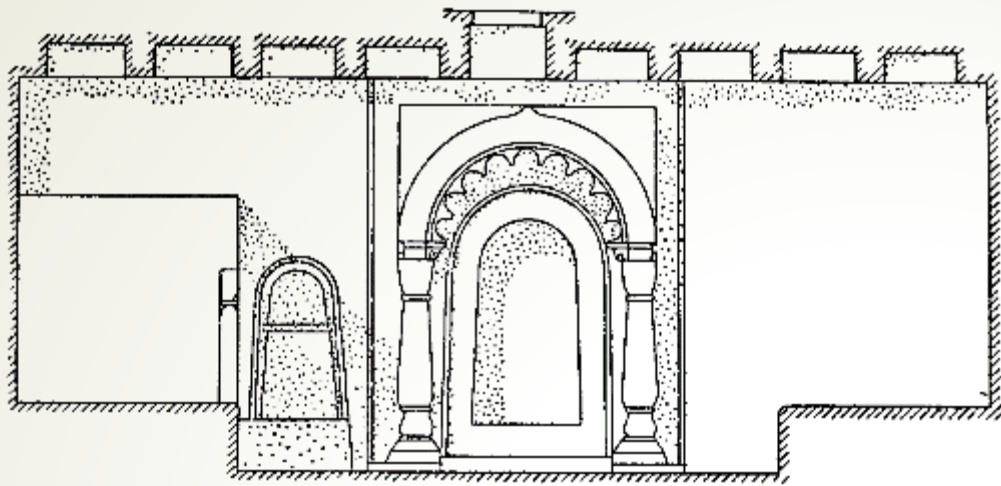

0 1 2M

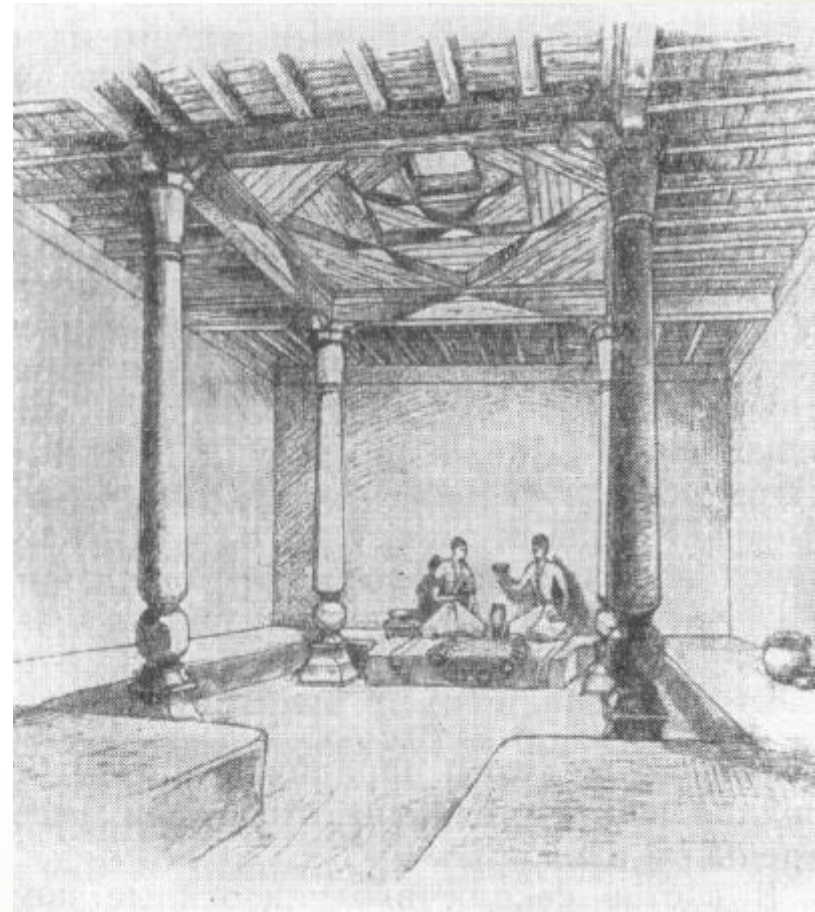



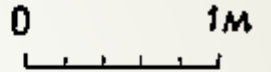
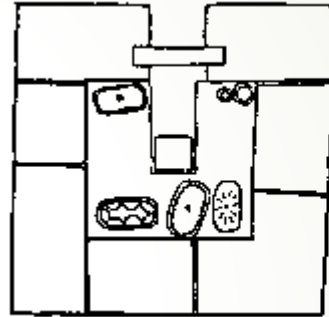
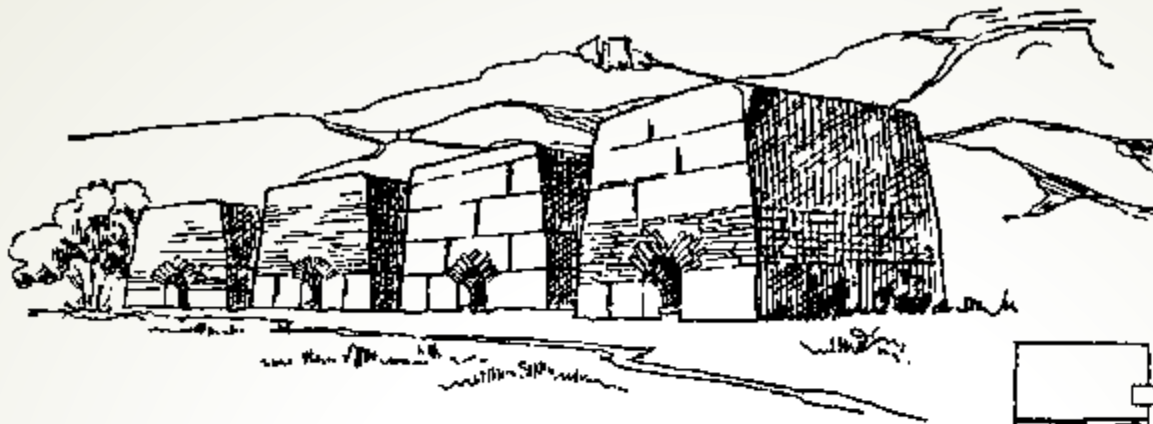











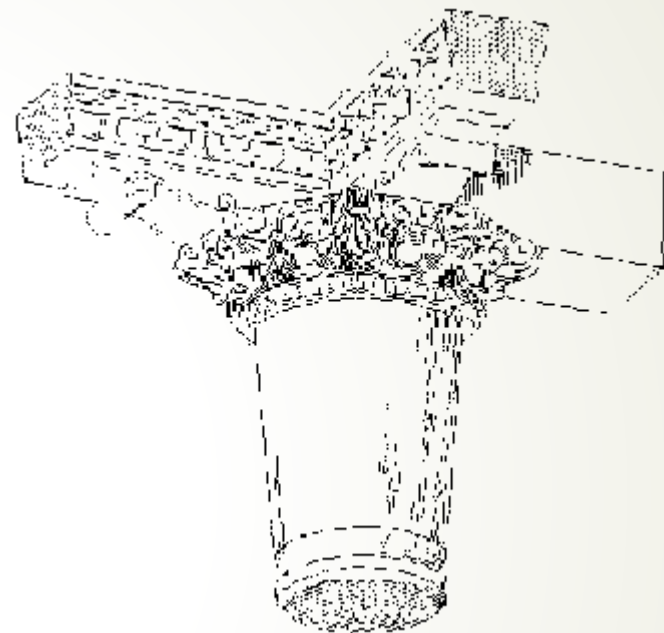
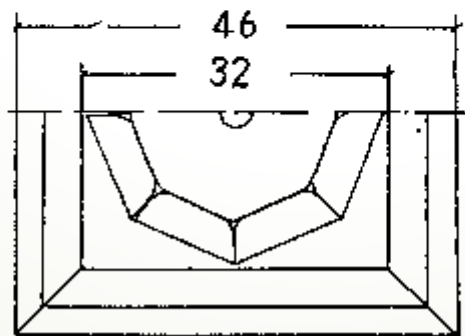
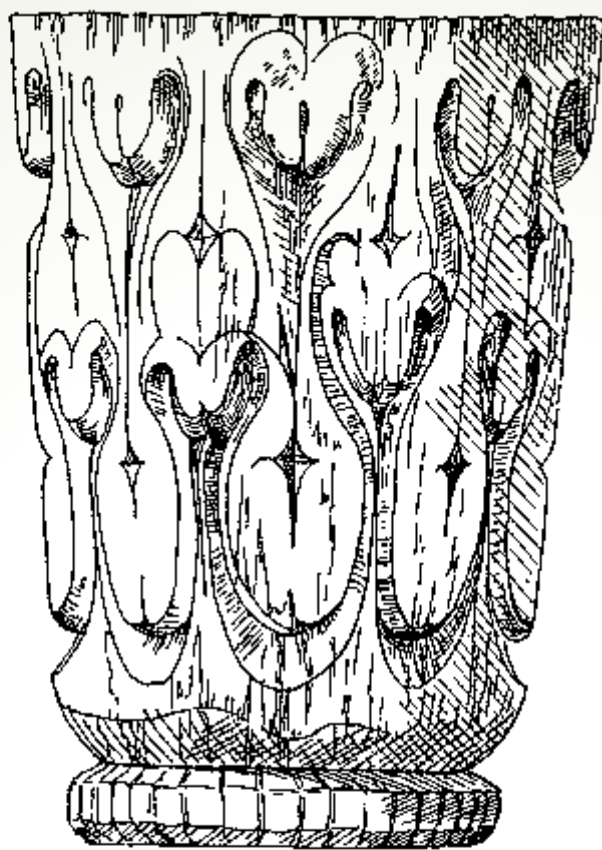
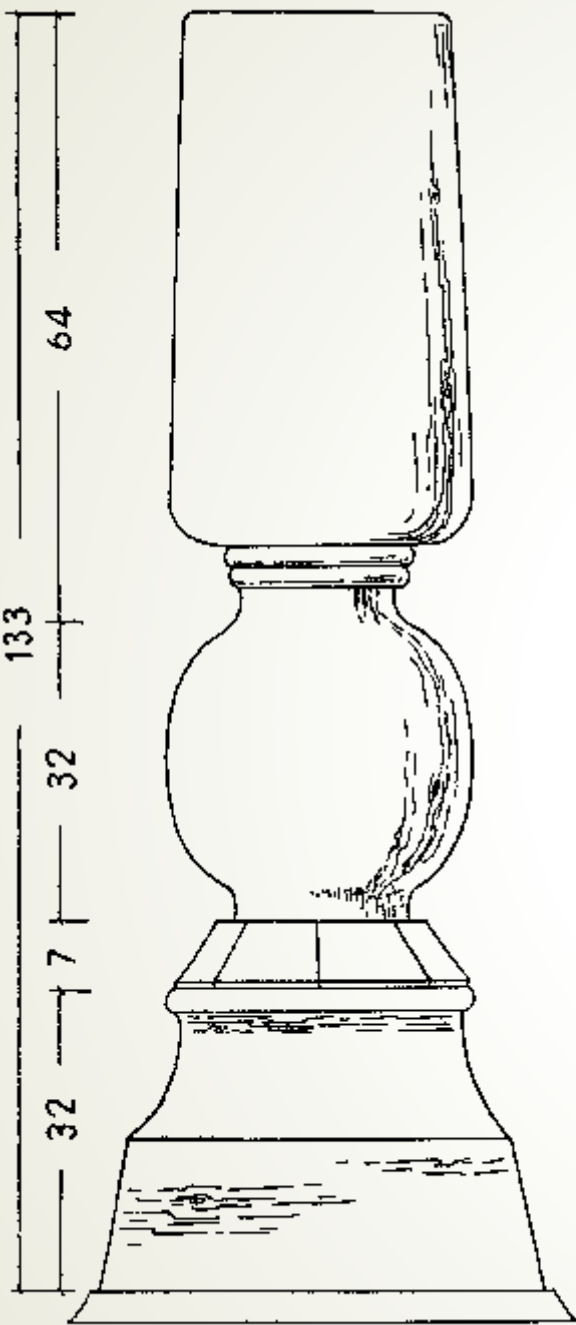

- Panjikent. Ustun - baza, kapitel va abaka



- Panjiket. Kariatida.
- Devor bezaklari

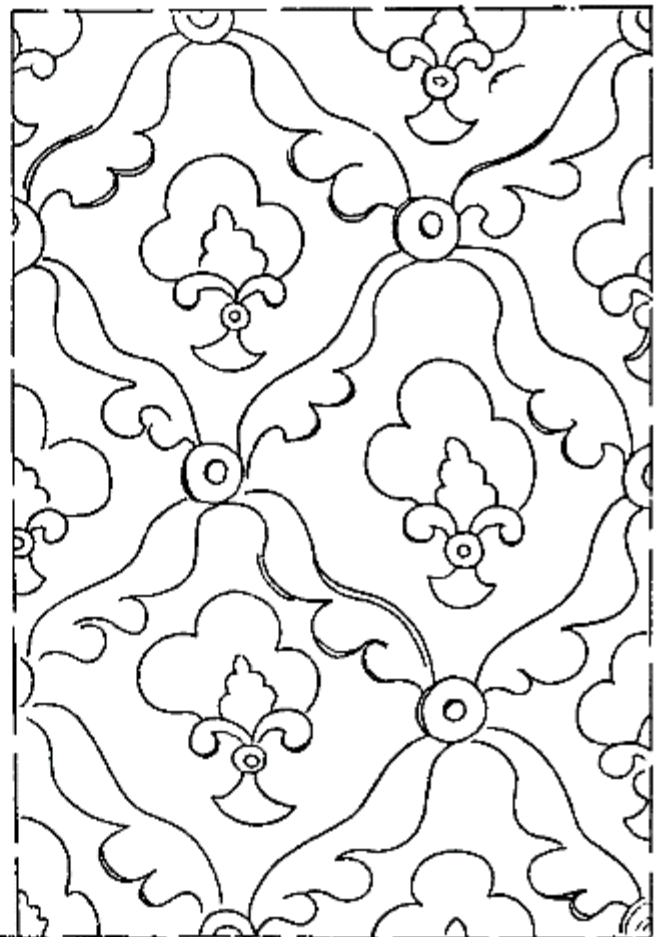
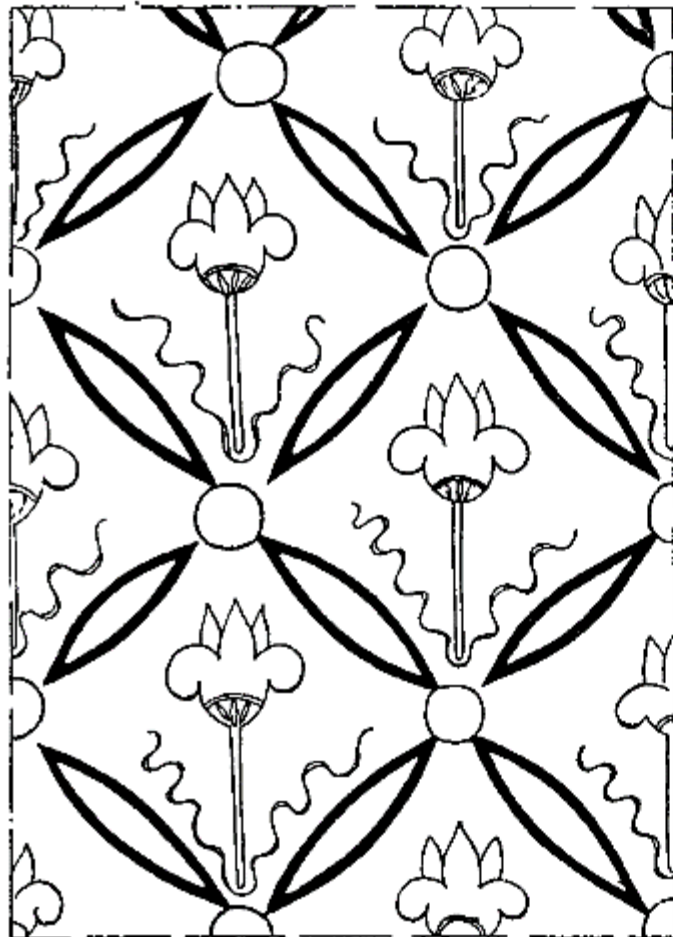



# Varaxsadagi Buxorxudotlar saroyi





# Varaxsadagi Buxorxudotlar saroyi rekonctruksiyasi

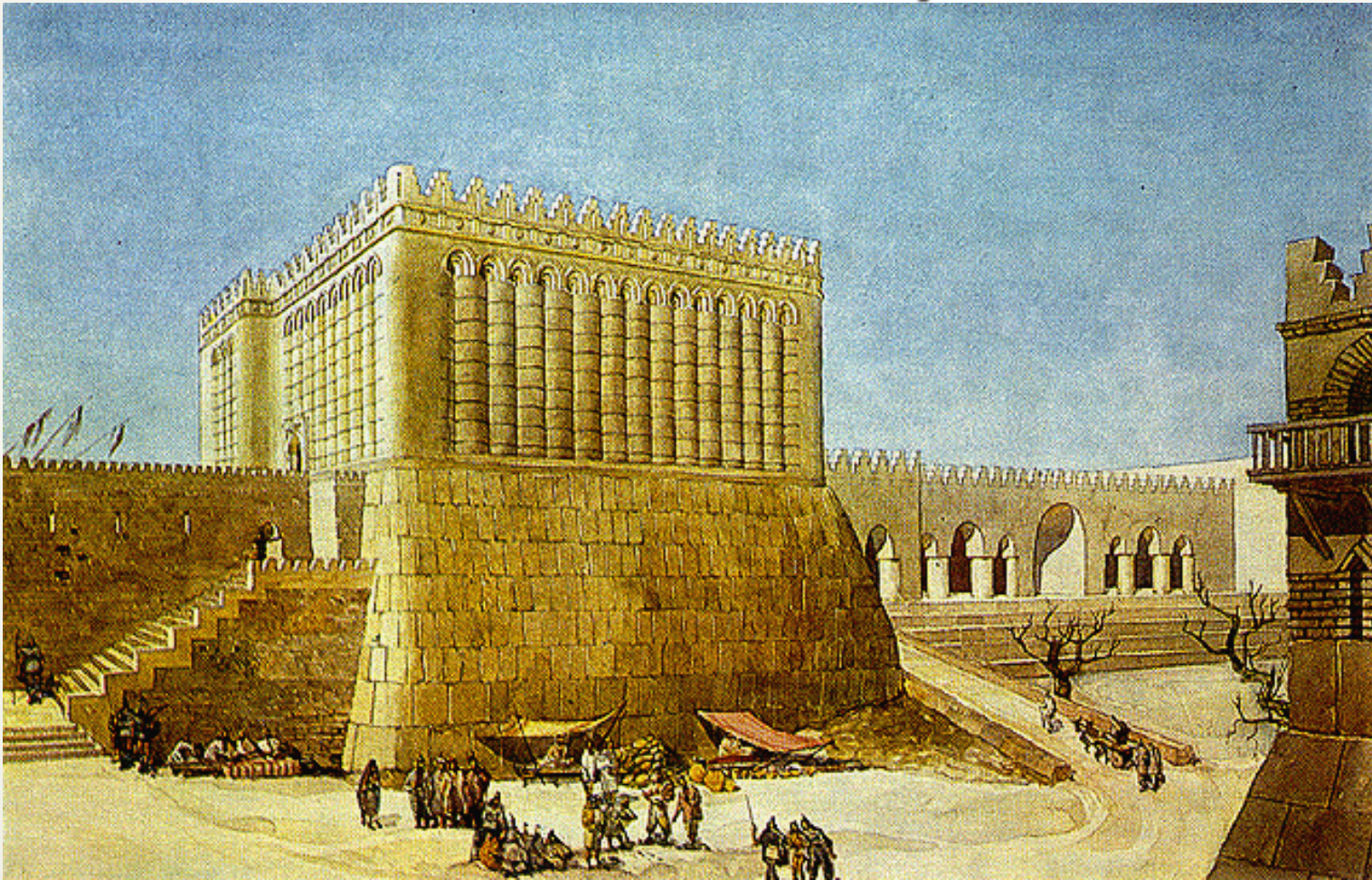





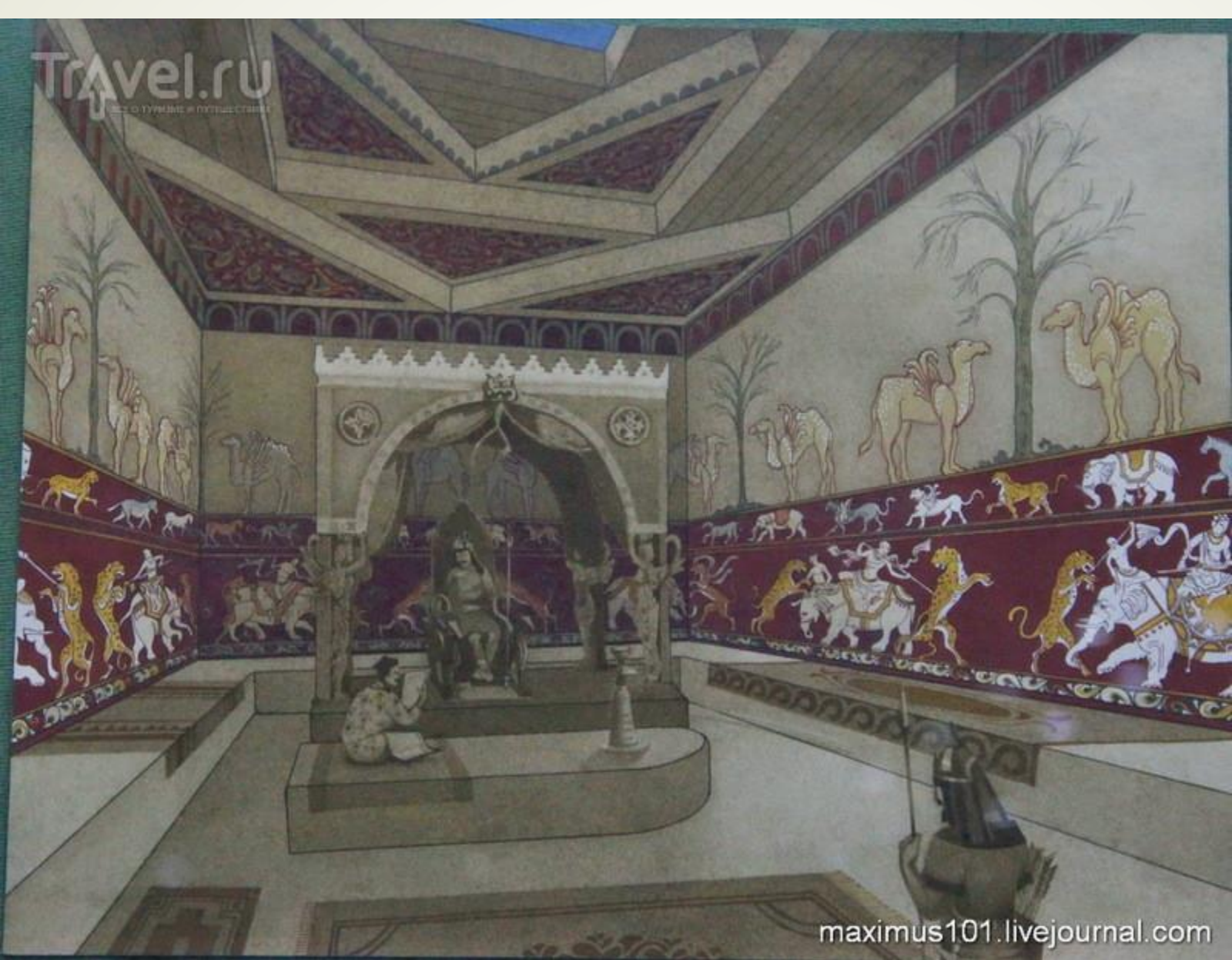





Варахшадаги Бухорхудотлар  
саройининг деворий суратлари  
(7 аср)









Central Asia  
TRAVEL

[www.centralasia-travel.com](http://www.centralasia-travel.com)





- Varaxsha. Shaarqiy devor. Shohning taqvosi



# Варахша топилмалари

















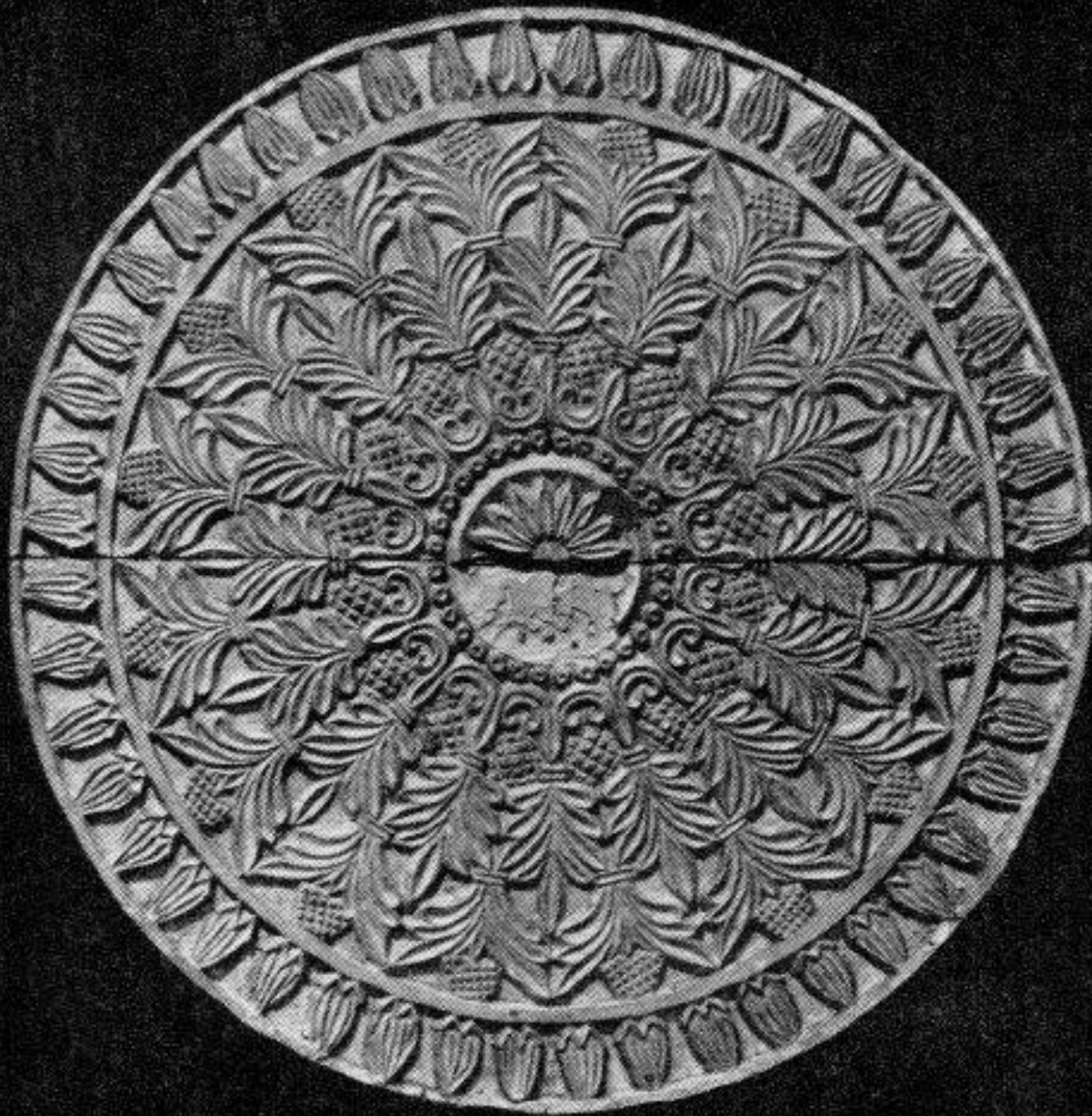

- Panno.  
7 asr



# Варахша топилмалари

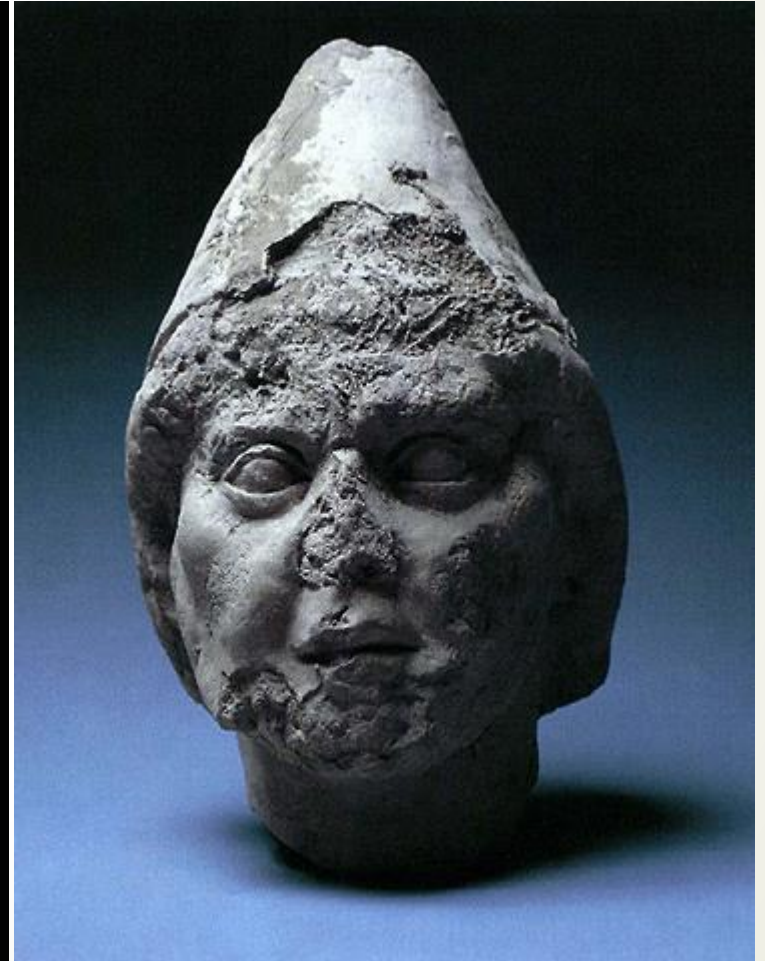



8-расм. Илк ўрта аср (V—VIII) лар меъморчилиги намуналари. Афросиёб (Қадимий Самарқанд) шаҳарчасининг марказий қисмида очилган деворий суратли тўражой комплекси.



# Афросиёб деворий суратлари

























- Афросиёбнинг Қорахонийлар даврига оид суратлари (XII аср охирлари– XIII аср бошлар)





# Xorazm. Qizilqal'a



# Тупроққалъа. “Жангчилар зали”

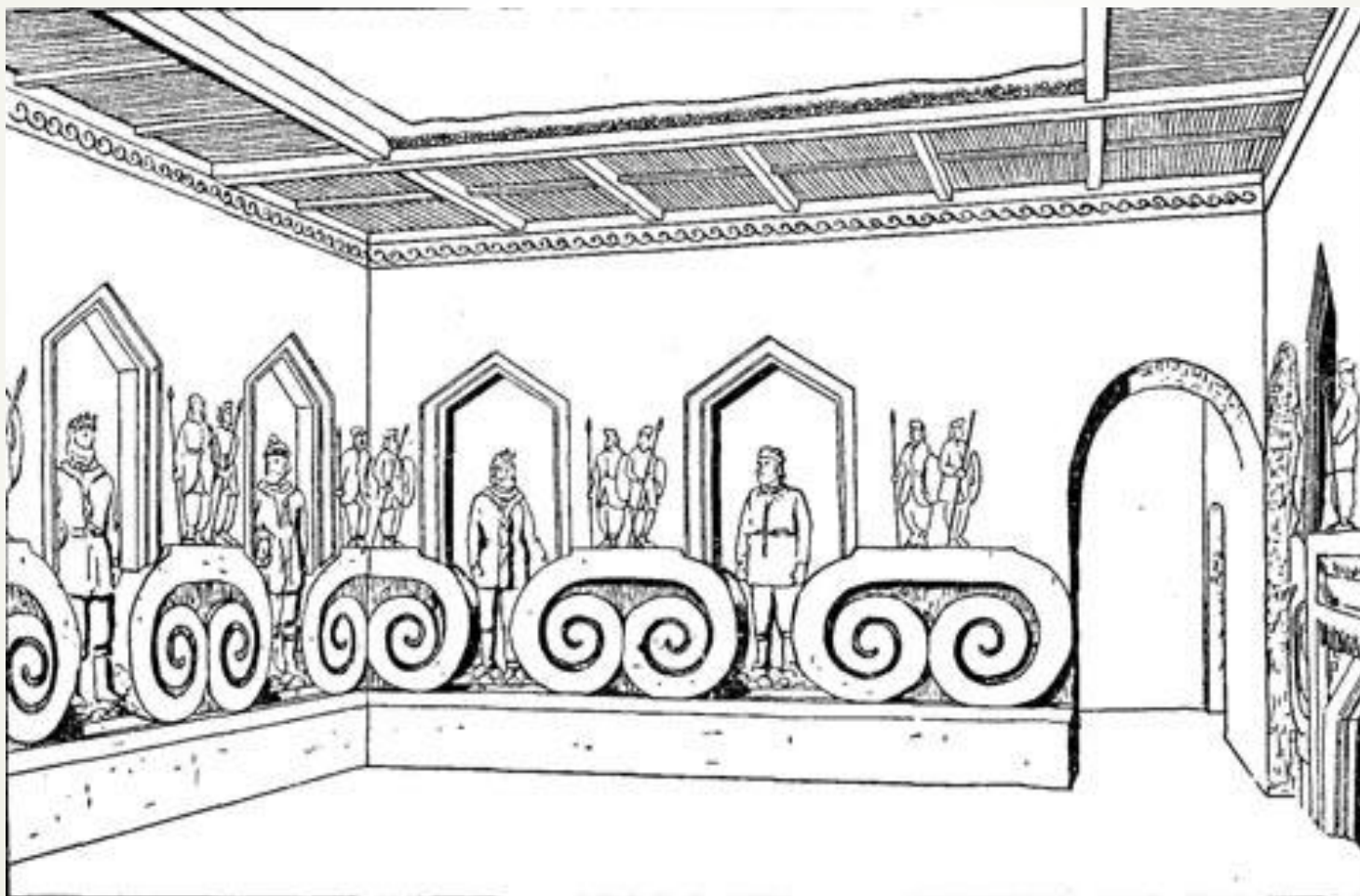



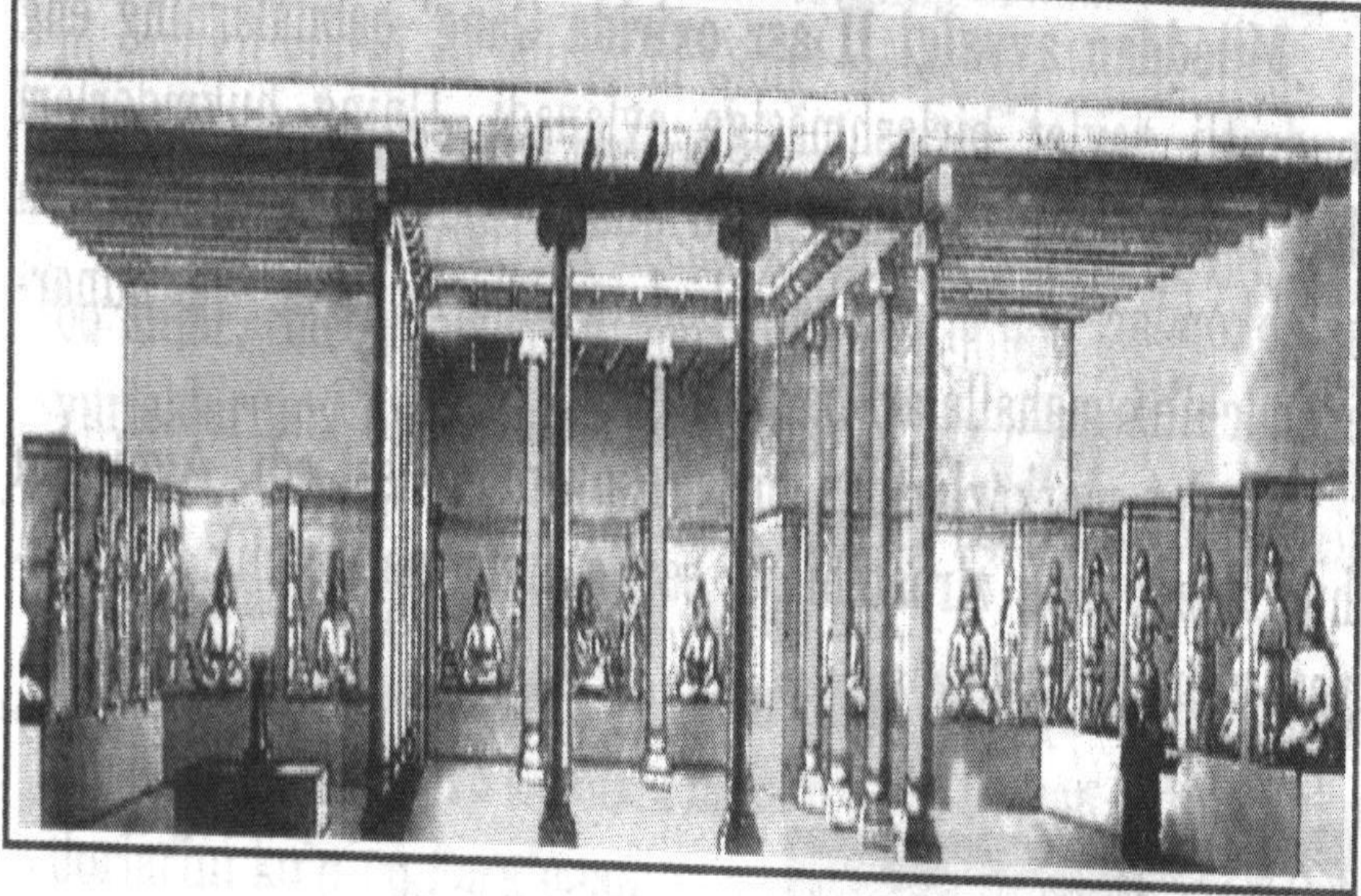

**Tuproqqal'a. Shohlar koshonasi.**



# Нирванадаги Будда. Ажинатепе





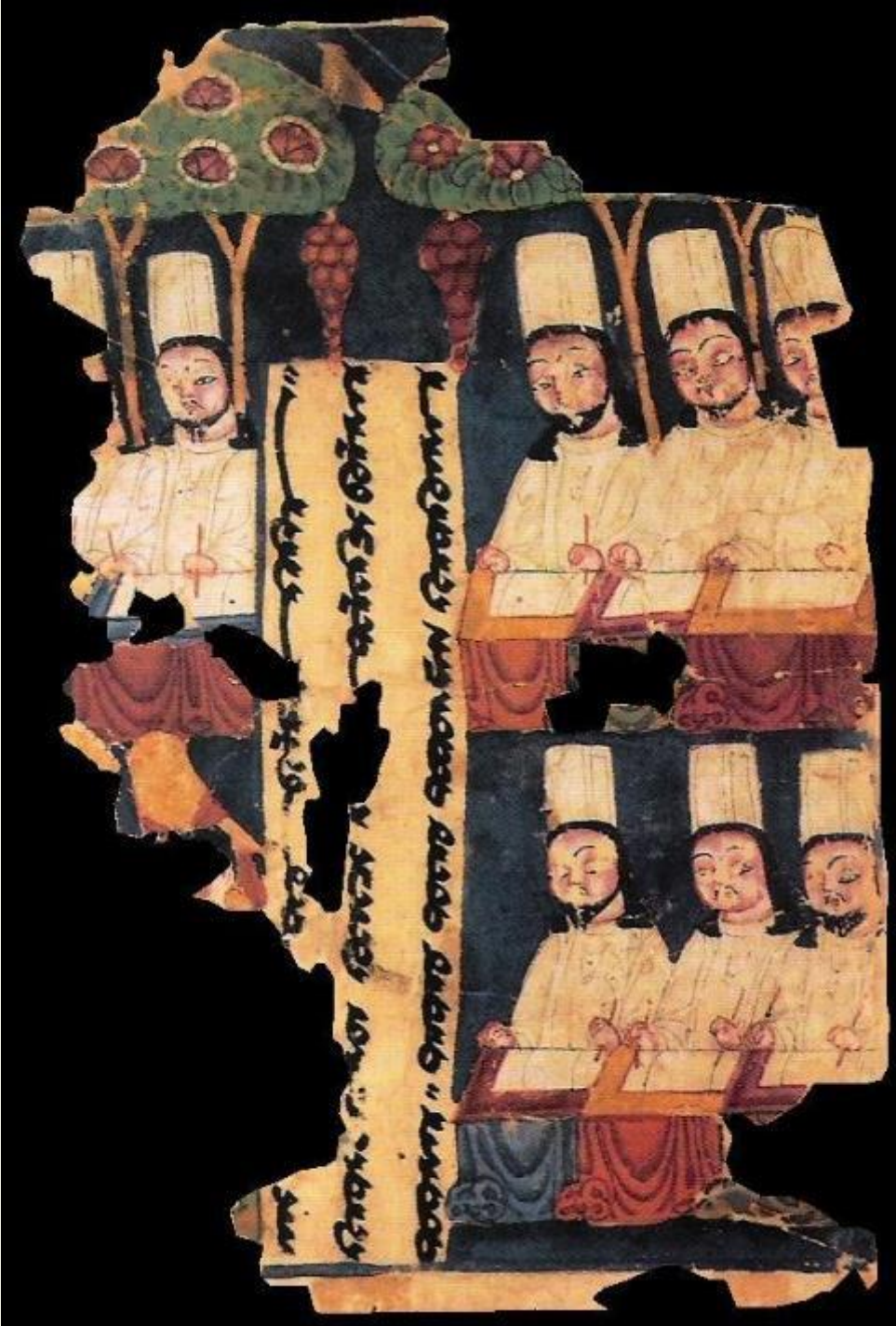

- Moniylik ruhoniylari.
- Tarim vodiysidan topilgan qo'lyozma.
- Maatn - so'g'd tilida.

# Уструшона. Қалъаи Қаҳқаҳа деворий сурати. VII-VIII аср

